

SARAY® | PVC

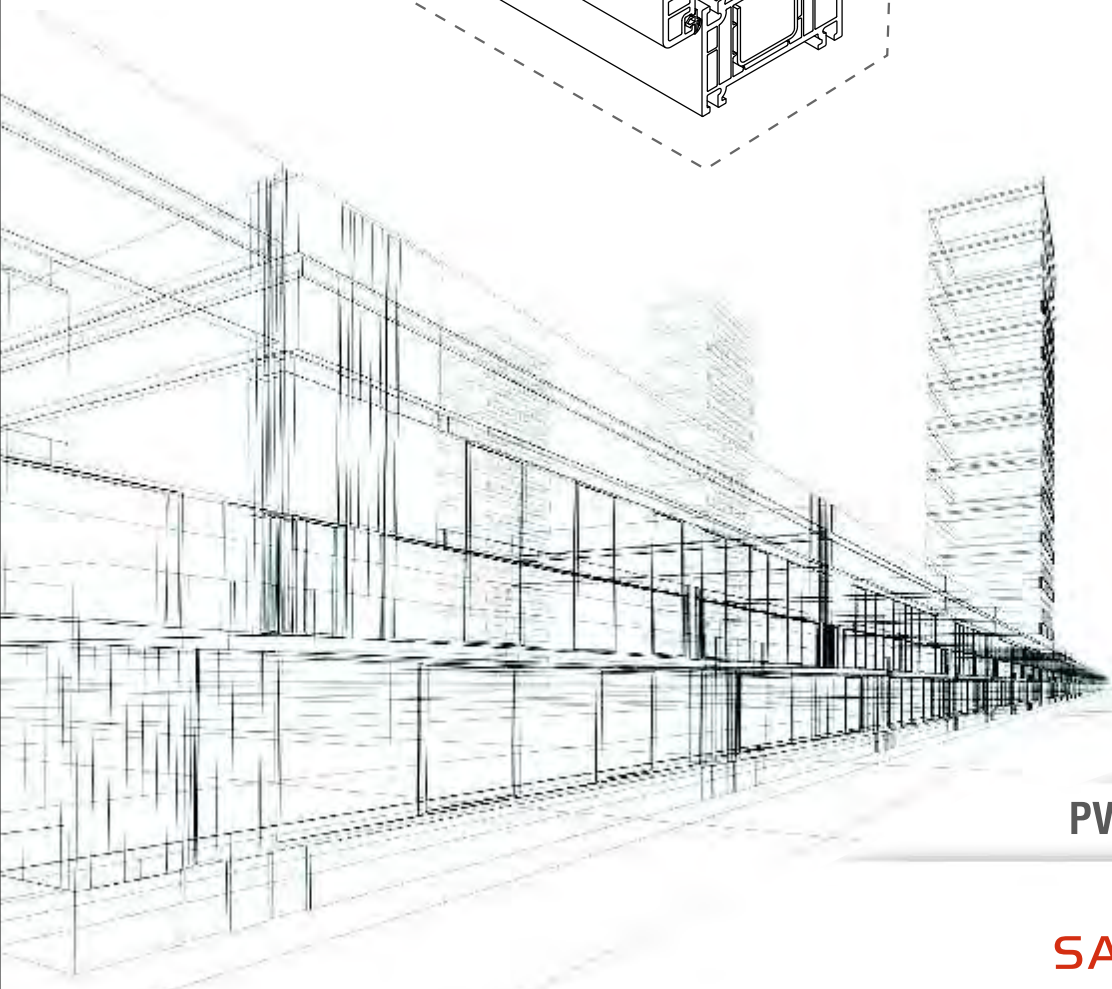
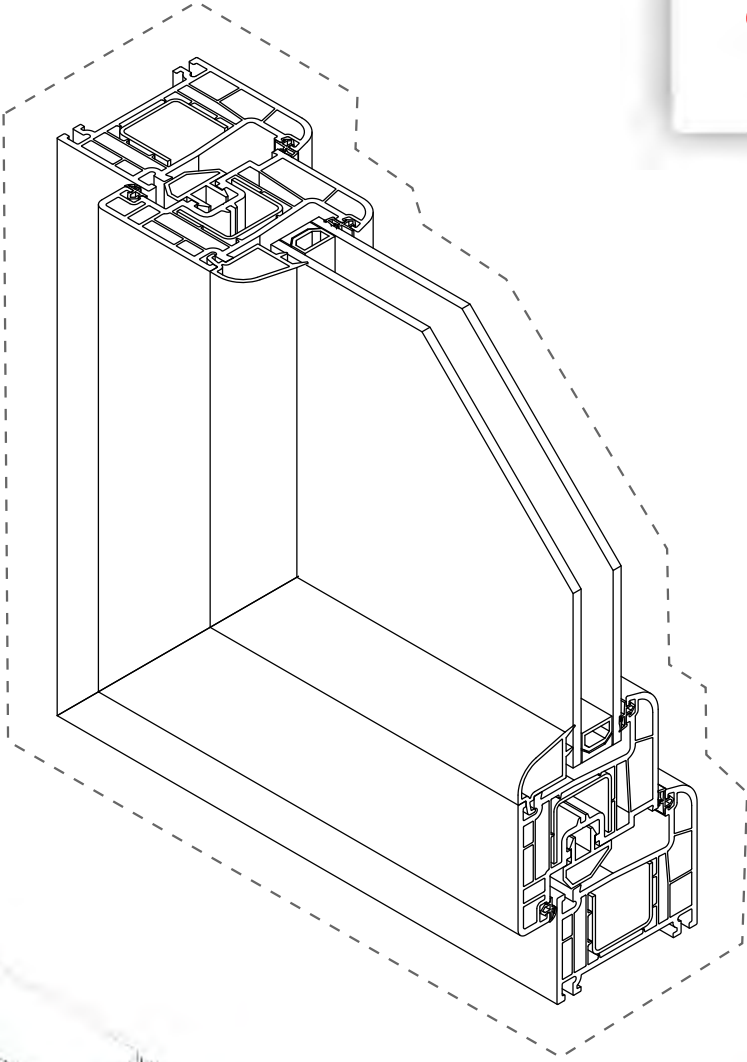

PVC KATALOG

SARAY® | Alüminyum

S60

ANA PROFİLLER MAIN PROFILES

SARAY® PVC

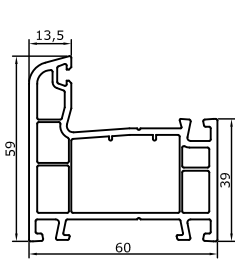

601
Kasa Profili
Frame Profile
0,950 kg/m

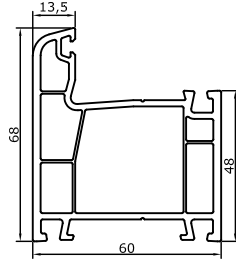

631
Kasa Profili
Frame Profile
1,005 kg/m

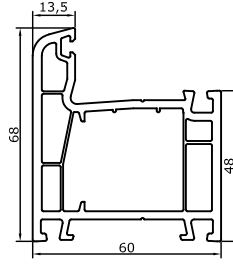

361
Kasa Profili
Frame Profile
1,170 kg/m

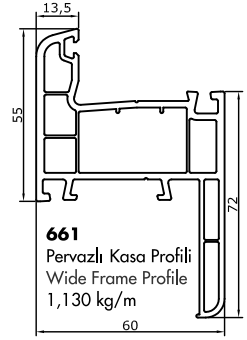

661
Pervazlı Kasa Profili
Wide Frame Profile
1,130 kg/m

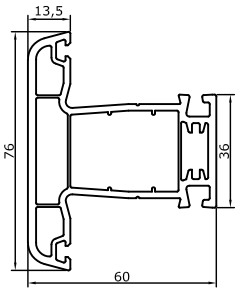

602
Orta Kayıt
Mullion Profili
1,050 kg/m

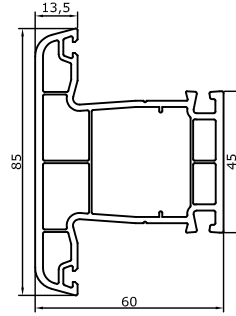

632
Orta Kayıt
Mullion Profili
1,100 kg/m

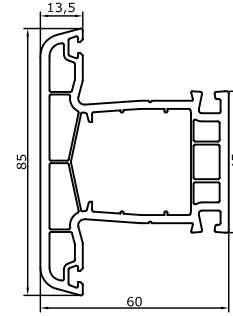

362
Orta Kayıt
Mullion Profili
1,300 kg/m

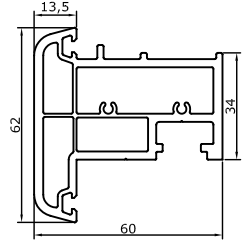

604
Hareketli Orta Kayıt
Overhang Profili
1,105 kg/m

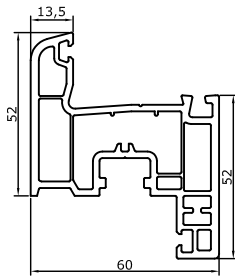

603
Kanat Profili
Sash Profile
1,125 kg/m

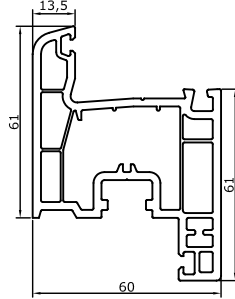

633
Kanat Profili
Sash Profile
1,280 kg/m

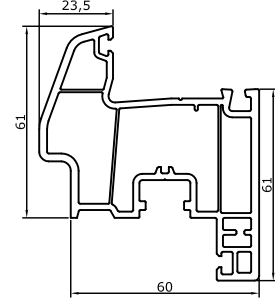

703
Damlalıklı Kanat Profili
Wide Sash Profile
1,230 kg/m

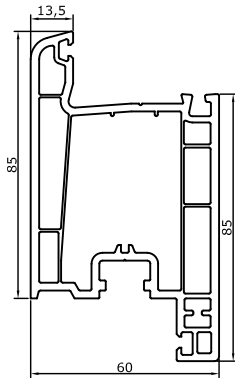

607
Dar Kapı Kanat Profili
Tight Door Sash Profile
1,520 kg/m

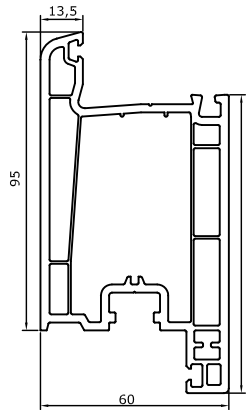

605
Kapı Kanat Profili
Door Sash Profile
1,730 kg/m

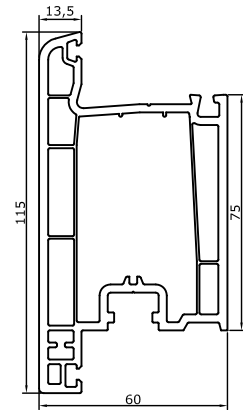

606
Dışa Açılır Kapı Profili
Outside Opening Door Profile
1,730 kg/m

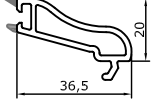

611
4 mm Tek Cam Çıtası
4 mm Single Glass Bead
0,265 kg/m

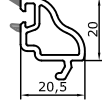

612
20 mm Çift Cam Çıtası
20 mm Double Glass Bead
0,205 kg/m

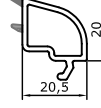

620
20 mm Çift Cam Çıtası
20 mm Double Glass Bead
0,170 kg/m

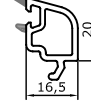

614
24 mm Çift Cam Çıtası
24 mm Double Glass Bead
0,180 kg/m

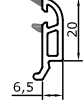

615
34 mm Üçlü Cam Çıtası
34 mm Triple Glass Bead
0,165 kg/m

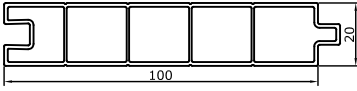

616
20 mm Lambri
Weinscott Profile 20 mm
0,540 kg/m

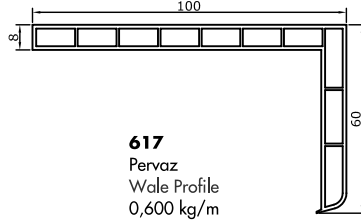

617
Pervaz
Wale Profile
0,600 kg/m

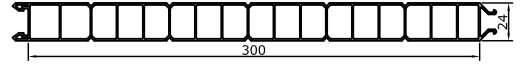

619
24 mm Lambri
Weinscott Profile 24 mm
1,700 kg/m

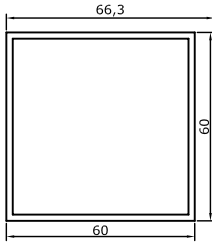

916/B
Köşe Dönüş Kutu Profili
Corner Box Profile
1,270 kg/m (Al) / 0,800 kg/m (PVC)

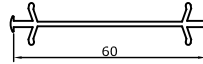

6506
İnce Bağ Profili
Connection Profile
0,390 kg/m (Al) / 0,380 kg/m (PVC)

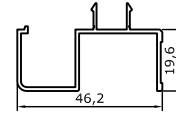

6512
Kapı Altı Fırça Profili
Door Under Brush Profile
0,395 kg/m

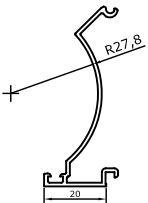

6507
Eksenel Dönüş Adaptörü
Corner Pipe Adaptor Profile
0,350 kg/m (Al) / 0,400 kg/m (PVC)

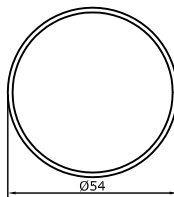

613
Eksenel Dönüş Borusu
Corner Pipe Profile
0,680 kg/m (Al) / 0,800 kg/m (PVC)

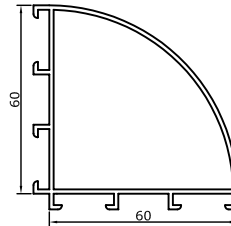

4186
90° Dönüş Profili
90° Corner Profile
1,020 kg/m

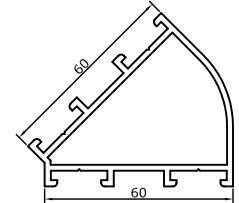

4150
135° Dönüş Profili
135° Corner Profile
1,180 kg/m

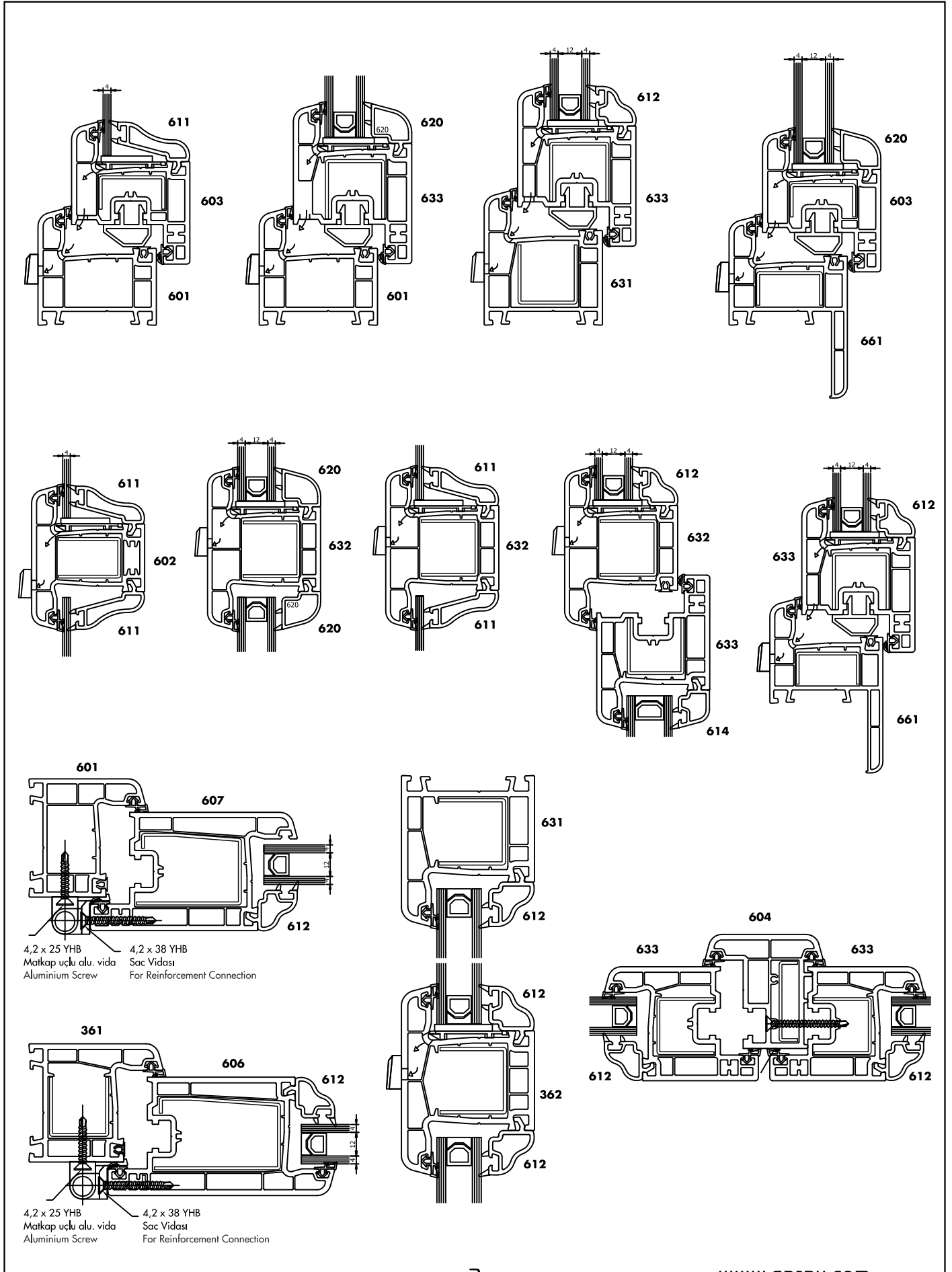

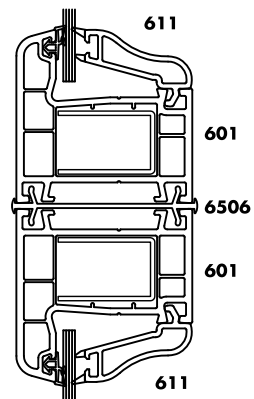
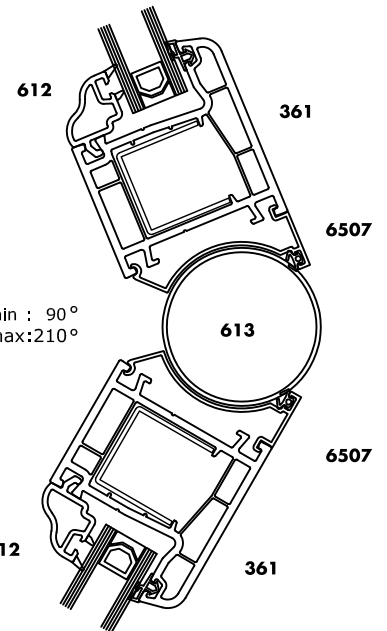
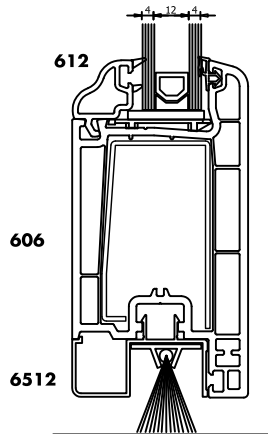
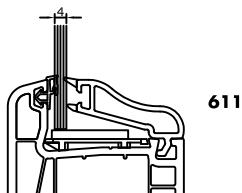
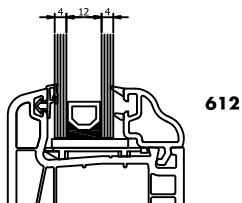
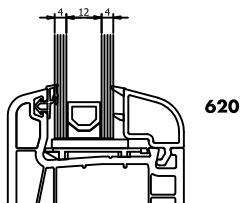
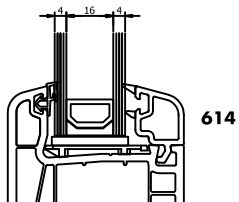
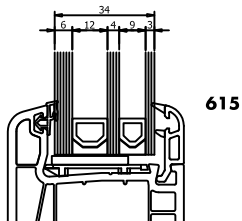
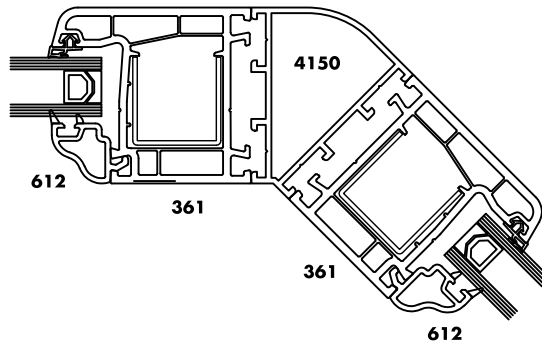
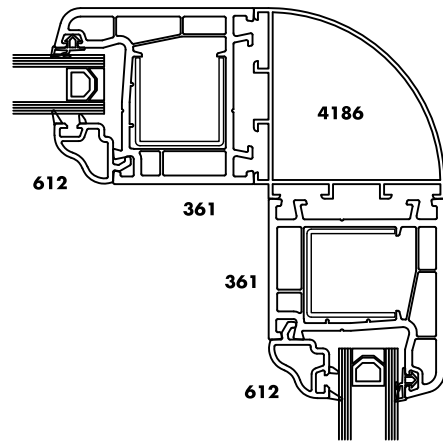
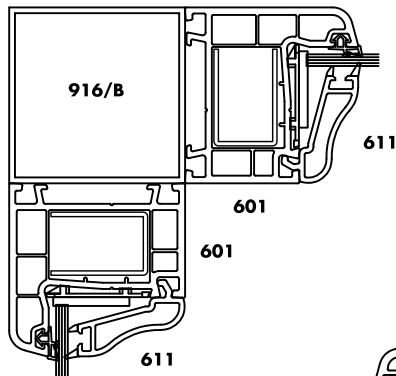

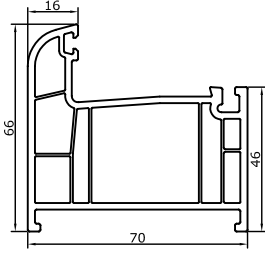

7031
Kasa Profili
Frame Profile
1,085 kg/m

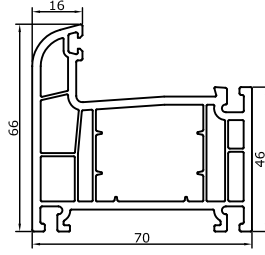

7001
Kasa Profili
Frame Profile
1,270 kg/m

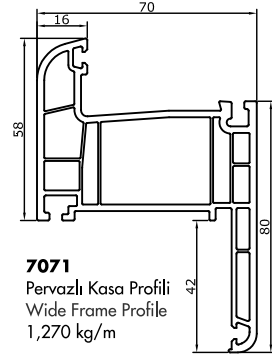

7071
Pervazlı Kasa Profili
Wide Frame Profile
1,270 kg/m

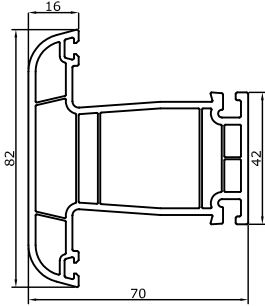

7032
Orta Kayıt
Mullion Profile
1,173kg/m

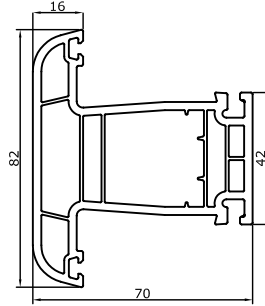

7002
Orta Kayıt
Mullion Profile
1,350 kg/m

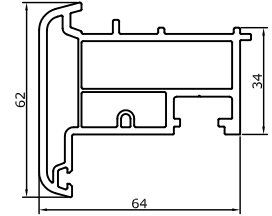

7004
Hareketli Orta Kayıt Profili
Overhang Profile
1,000 kg/m

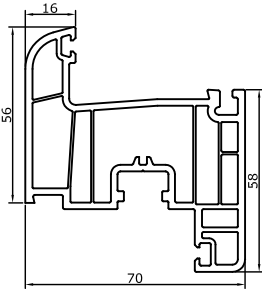

7033
Kanat Profili
Sash Profile
1,252 kg/m

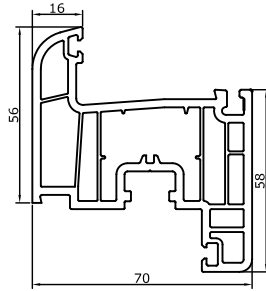

7003
Kanat Profili
Sash Profile
1,440 kg/m

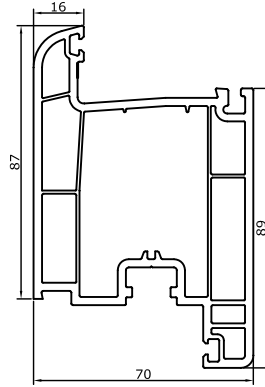

7005
Kapı Kanat Profili
Door Sash Profile
1,700 kg/m

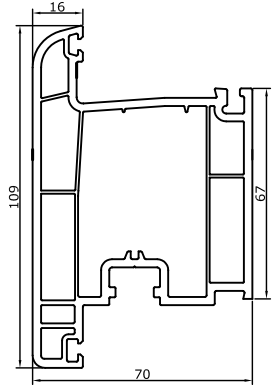

7006
Dışa Açılır Kapı Kanat Profili
Outside Opening Door Sash
1,700 kg/m

YARDIMCI PROFİLLER / SHARED PROFILES

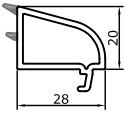

7012
20 mm Çift Cam Çıtası
20 mm Double Glas Bead
0,230 kg/m

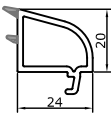

7014
24 mm Çift Cam Çıtası
24 mm Double Glas Bead
0,210 kg/m

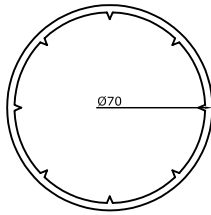

7021
Eksenel Dönüş Borusu
Corner Pipe
0,850 kg/m

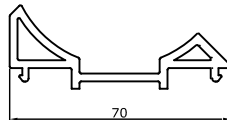

7022
Eksenel Dönüş Adaptörü
Corner Pipe Adapter
0,450 kg/m

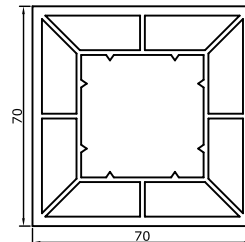

7023
Köşe Dönüş Kutu Profili
Corner Box Profile
1,400 kg/m

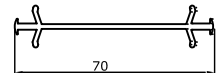

6505
İnce Bağ Profili
Connection Profile
0,390 kg/m (Al) / 0,380 kg/m (PVC)

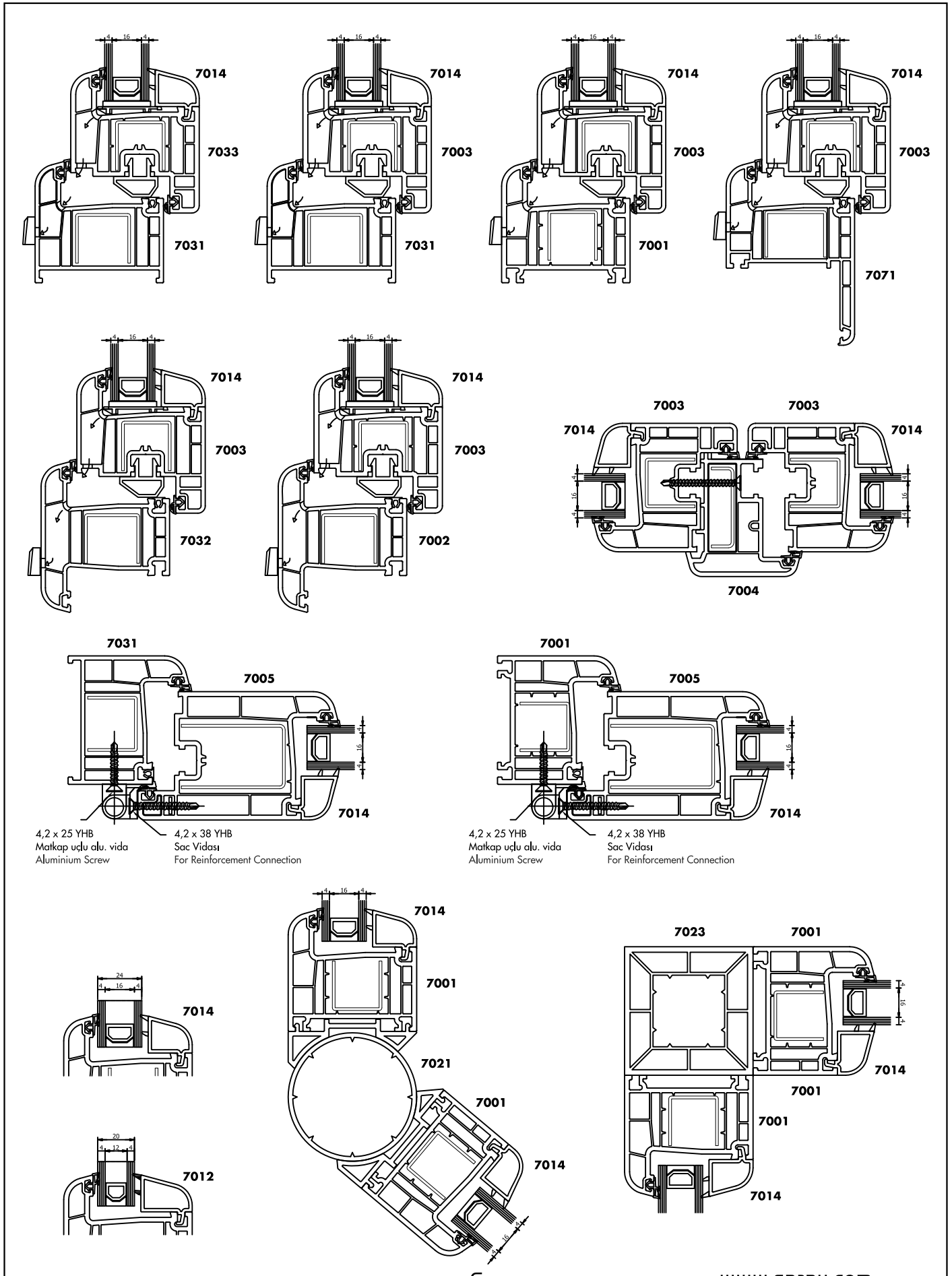

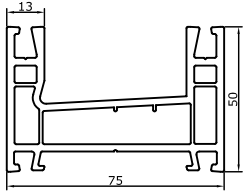

751
Sürme Kasa
Sliding Frame
1,280 kg/m

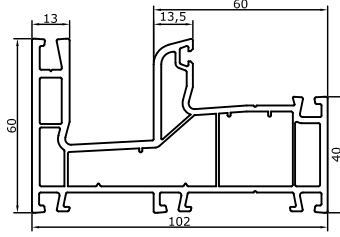

755
Sürme Fiks Kasa
Fix Sliding Frame
1,625 kg/m

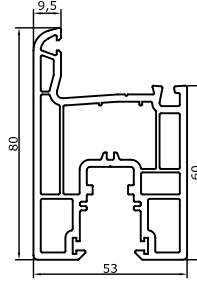

752
Sürme Kanat
Sliding Sash
1,400 kg/m

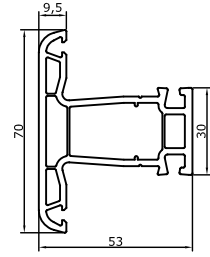

753
Sürme Orta Kayıt
Sliding Mullion
0,905 kg/m

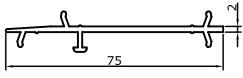

754
Sürme Bağlantı
Sliding Connection
0,520 kg/m

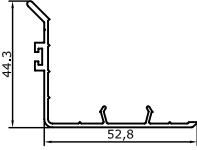

6505
Sürme Kenet Profili
Interlock Profile
0,455 kg/m

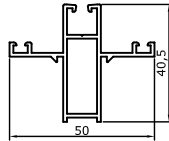

6511
Birleşim Adaptörü
Connection Profile
0,620 kg/m

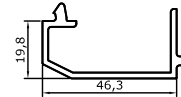

6516
Fiks Kasa Kapak Pr.
Sliding Fix Frame Cap
0,590 kg/m

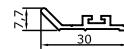

6517
Küçük Kenet Profili
Small Interlock
0,190 kg/m



6503
Sürme Ray
Sliding Roll
0,094 kg/m

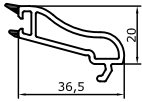

611
4 mm Tek Cam Çıtası
4 mm Single Glass Bead
0,265 kg/m

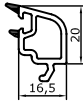

614
24 mm Çift Cam Çıtası
24 mm Double Glass Bead
0,180 kg/m

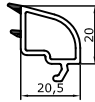

620
20 mm Çift Cam Çıtası
20 mm Double Glass Bead
0,170 kg/m

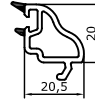

612
20 mm Çift Cam Çıtası
20 mm Double Glass Bead
0,205 kg/m

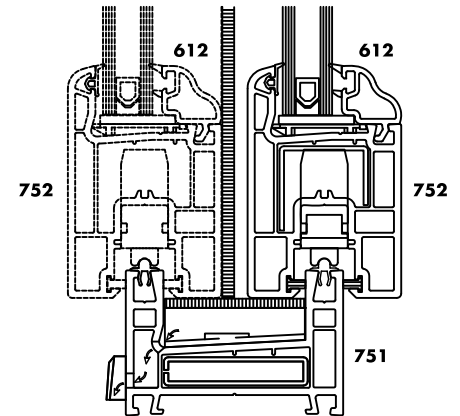
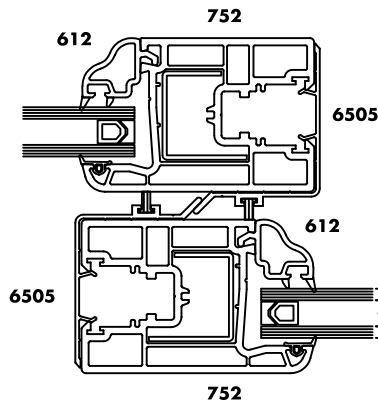
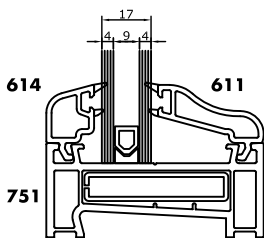
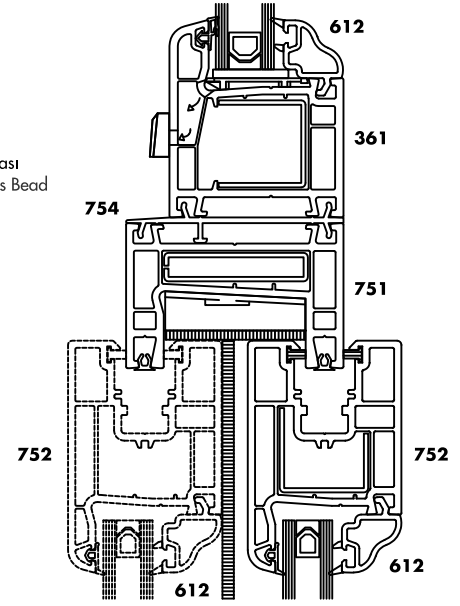
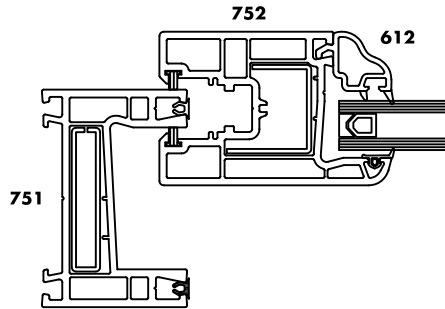
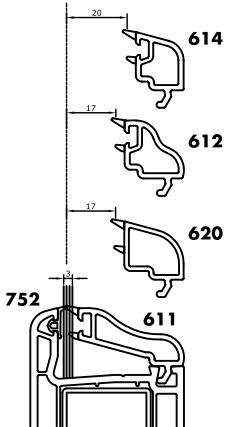

S750

SÜRME DETAYLAR SLIDING DETAILS

SARAY® PVC

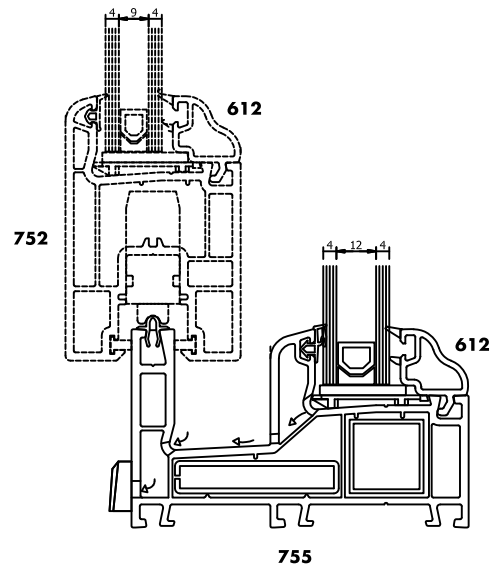
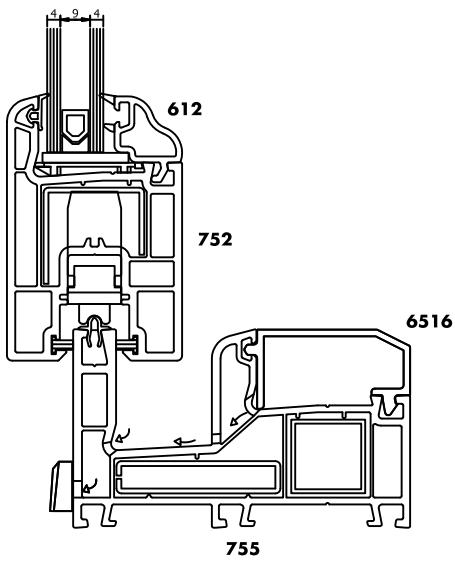
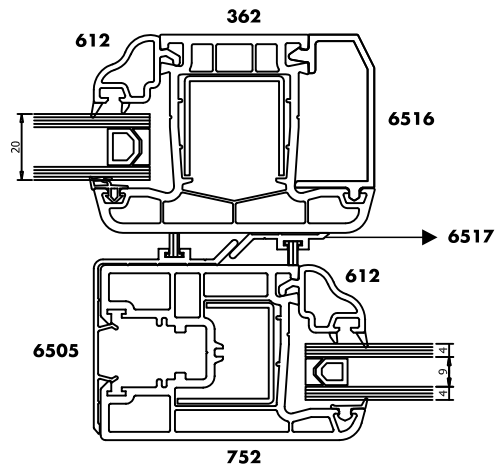
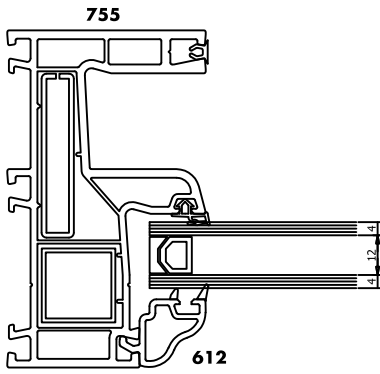
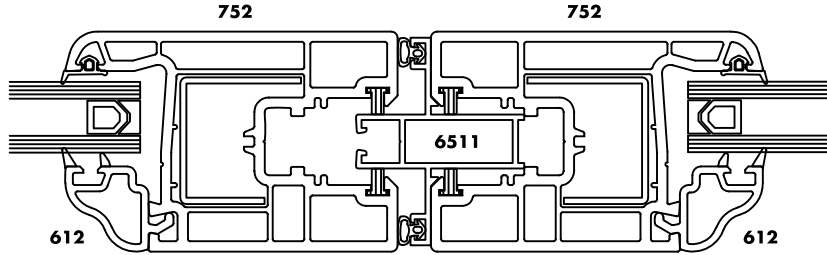

S790

SİNELİKLİ SÜRME SLIDING SWAFTER SYSTEM

SARAY® PVC

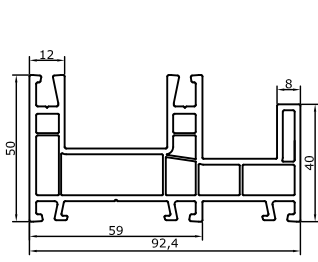

791
Sürme Sineklikli Kasa
3 Track Sliding Frame Profile
1,350 kg/m

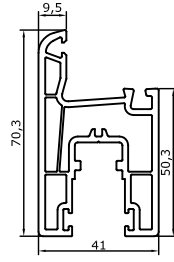

793
Sürme Kanat
Sliding Sash Profile
0,960 kg/m

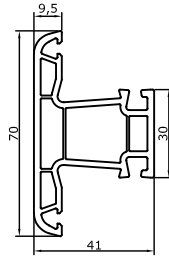

792
Sürme Orta Kayıt
Sliding Mullion
0,735 kg/m

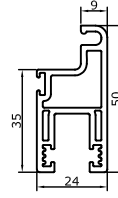

795
S. Sineklikli Kanat
Sliding Swaffer Sash Pr.
0,511 kg/m

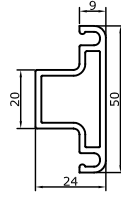

794
S. Sineklikli Orta Kayıt
Sliding Swaffer Mullion Pr.
0,369 kg/m

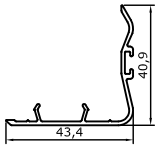

796
Sürme Kanat Kapama (interlok)
Interlock Profile
0,185 kg/m

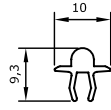

6503
Sürme Ray
Sliding Roll
0,094 kg/m

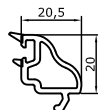

612
Sürme Tek Cam Çıtası
Sliding Single Glassing Bead Pr.
0,205 kg/m

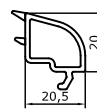

620
Sürme Tek Cam Çıtası
Sliding Single Glassing Bead Pr.
0,170 kg/m





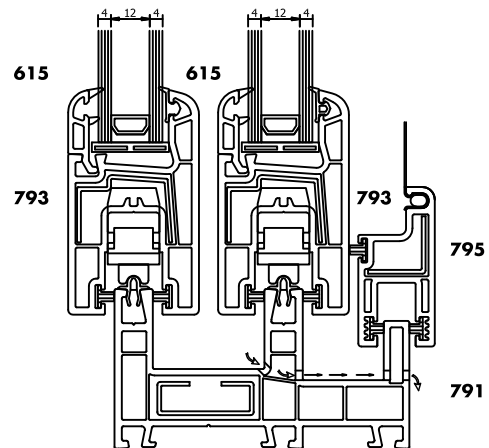
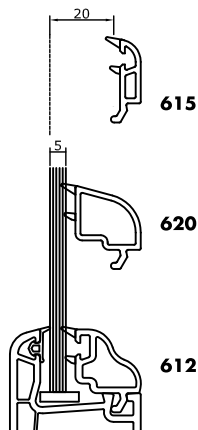
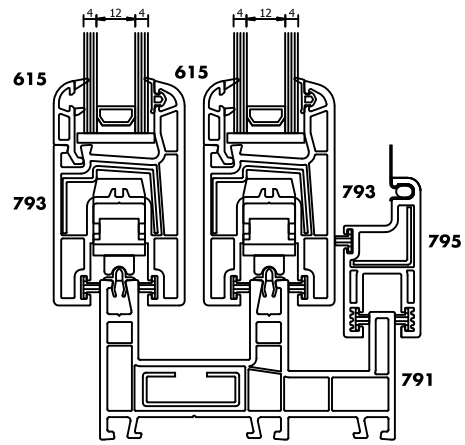
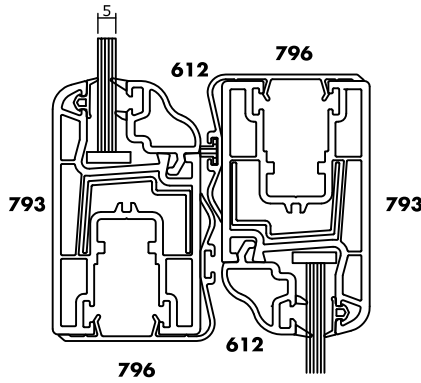







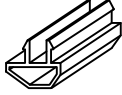
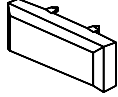

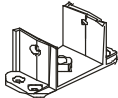

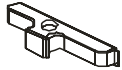

615
Sürme 20 mm Çift Cam Çıtası
Sliding Double Glassing Bead Pr.
0,165 kg/m

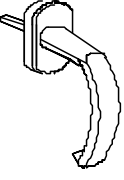

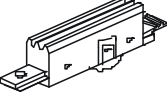
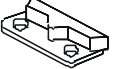
TÜM SERİLER İÇİN DESTEK SAÇLARI / SUPPORTING PROFILES

Kod Code	Profiller Profiles	Şekli Drawings	Et Kalınlığı Wall Thickness	B. Ağırlığı (kg/m) Brut Weight (kg/m)
SD-01	361-362-363 631-632 633-703		1,25 mm	0,830 kg/m
SD-02			1,55 mm	0,995 kg/m
SD-03			2,00 mm	1,325 kg/m
SD-04	361-631		1,25 mm	1,080 kg/m
SD-05			1,55 mm	1,340 kg/m
SD-06			2,00 mm	1,725 kg/m
SD-07	604		1,25 mm	0,575 kg/m
SD-08			1,55 mm	0,715 kg/m
SD-09			2,00 mm	0,920 kg/m
SD-10	605-606		1,25 mm	1,590 kg/m
SD-11			1,55 mm	1,970 kg/m
SD-12			2,00 mm	2,545 kg/m
SD-13	601-602		1,25 mm	0,790 kg/m
SD-14			1,55 mm	0,980 kg/m
SD-15			2,00 mm	1,265 kg/m
SD-16	603-661		1,25 mm	0,625 kg/m
SD-17			1,55 mm	0,775 kg/m
SD-18			2,00 mm	0,995 kg/m
SD-19	752		1,25 mm	0,725 kg/m
SD-20			1,55 mm	0,895 kg/m
SD-21			2,00 mm	1,155 kg/m
SD-22	751-755		1,25 mm	1,060 kg/m
SD-23			1,55 mm	1,315 kg/m
SD-24			2,00 mm	1,695 kg/m
SD-26	7001-7002-7003 7031 - 7032 - 7033		1,25 mm	0,790 kg/m
SD-27			1,55 mm	0,980 kg/m
SD-28			2,00 mm	1,265 kg/m
SD-29	7004		1,25 mm	0,605 kg/m
SD-30			1,55 mm	0,750 kg/m
SD-31			2,00 mm	0,970 kg/m
SD-32	7005-7006		1,25 mm	1,405 kg/m
SD-33			1,55 mm	1,745 kg/m
SD-34			2,00 mm	2,250 kg/m
SD-35	755		1,25 mm	0,800 kg/m
SD-36			1,55 mm	0,995 kg/m
SD-37			2,00 mm	1,280 kg/m
SD-38	753		1,25 mm	0,655 kg/m
SD-39			1,55 mm	0,810 kg/m
SD-40			2,00 mm	1,045 kg/m
SD-41	607		1,25 mm	1,335 kg/m
SD-42			1,55 mm	1,600 kg/m
SD-43			2,00 mm	2,137 kg/m
SD-44	7071		1,25 mm	0,805 kg/m
SD-45			1,55 mm	0,998 kg/m
SD-46			2,00 mm	1,287 kg/m
SD-47	791		1,25 mm	0,677 kg/m
SD-48			1,55 mm	0,840 kg/m
SD-49			2,00 mm	1,083 kg/m
SD-50	792		1,25 mm	0,442 kg/m
SD-51			1,55 mm	0,547 kg/m
SD-52			2,00 mm	0,707 kg/m
SD-53	793		1,25 mm	0,510 kg/m
SD-54			1,55 mm	0,633 kg/m
SD-55			2,00 mm	0,816 kg/m
SD-56	794		1,25 mm	0,412 kg/m
SD-57			1,55 mm	0,511 kg/m
SD-58			2,00 mm	0,659 kg/m
SD-59	795		1,25 mm	0,314 kg/m
SD-60			1,55 mm	0,389 kg/m
SD-61			2,00 mm	0,502 kg/m
SD-25	Menteşe/Wing Support		1,55 mm	0,080 kg/m

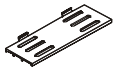
Aksesuar Resmi Picture	Aksesuar Kodu Code	Aksesuarın Adı Name	Paket Miktarı Package Qnt.
	SA-01	EPDM Kasa Kanat Contası Gasket for Frame and Sash	330 m / koli 330 m / package
	SA-02	EPDM Cam Contası Gasket	310 m / koli 310 m / package
	SA-03	Kanal Kapama Profili PVC Channel Closing	300 m / koli 300 m / package
	SA-04	Kanat Kaldırma Takoza Sash Support Piece	1000 ad / koli 1000 pcs / package
	SA-04 Kahve / Brown		
	SA-05	Su Tahliye Tapası Water Exit Cap	1000 ad / koli 1000 pcs / package
	SA-05 Kahve / Brown		
	SA-06	Montaj Tapası Assemble Cap	2000 ad / koli 2000 pcs / package
	SA-06 Kahve / Brown		
	SA-07	S60 Geniş Orta Kayıt Bağlantı Elemanı Mullion Connection	100 ad / koli 100 pcs / package
	SA-08	S60 Dar Orta Kayıt Bağlantı Elemanı Mullion Connection	
	SA-09	Cam Takoza Glass Support Piece	100 ad / koli 100 pcs / package
	SA-10	Zamak Karşılık Closing Adapter	100 ad / koli 100 pcs / package
	SA-11	S60 Hareketli Orta Kayıt Adaptörü Overhang Adapter	40 ad / koli 20 sağ - 20 sol
	SA-11 Kahve / Brown		40 pcs / package 20 left - 20 right

Aksesuar Resmi Picture	Aksesuar Kodu Code	Aksesuarın Adı Name	Paket Miktarı Package Qnt.
	SA-12	Pencere Menteşe Hinge for Window	50 ad / koli 50 pcs / package
	SA-12 Kahve/Brown		
	SA-13	Kapı Menteşesi Hinge for Door	40 ad / koli 40 pcs / package
	SA-13 Kahve/Brown		
	SA-14 G	Alüminyum Pencere Kolu Aluminium Window Handle	100 ad / koli 100 pcs / package
	SA-14 G Kahve/Brown		
	SA-14 B	Alüminyum Kapı Kolu Aluminium Door Handle	30 ad / koli 30 pcs / package
	SA-14 B Kahve/Brown		
	SA-15	Plastic Kol Plastic Handle	200 ad / koli 200 pcs / package
	SA-15 Kahve/Brown		
	SA-17	Kıl Fital Brush for Sliding System	800 m / koli 800 m / package
	SA-18 / 1	Pencere Sürme Makara Roller for Sliding Window	250 ad/ koli 250 pcs / package
	SA-18 / 2	Kapı Sürme Makara Roller for Sliding Door	100 ad/ koli 100 pcs / package
	SA-20	Hareketli Orta Kayıt Zamak Karşılığı Closing Adapter for Overhang	1000 ad/ koli 1000 pcs / package
	SA-23	Sürme Orta Kayıt Bağlantı Mullion Connection for Sliding Systems	100 ad/ koli 100 pcs / package
	SA-24	Sızdırmazlık Sliding Isolation Piece	100 ad/ koli 100 pcs / package
	SA-25	S70 Orta Kayıt Bağlantısı Mullion Connection for S70	100 ad/ koli 100 pcs / package
	SA-26	S70 Cam Takozu Glass Support Piece for S70	1000 ad/ koli 1000 pcs / package
	SA-27	S70 Hareketli Orta Kayıt Adaptörü Adapter for Overhang S70	40 ad/ koli 40 pcs / package
	SA-27 Kahve/Brown		

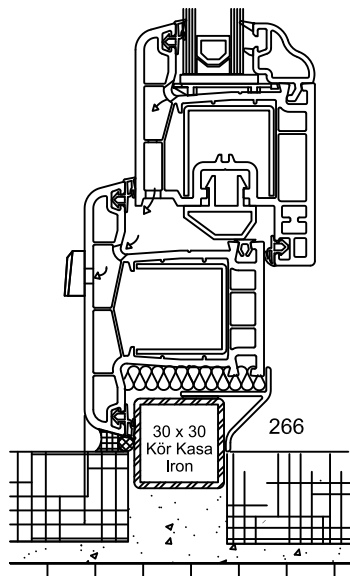
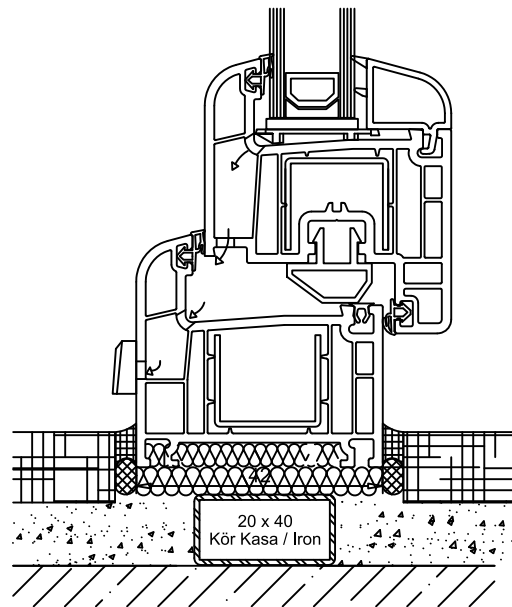
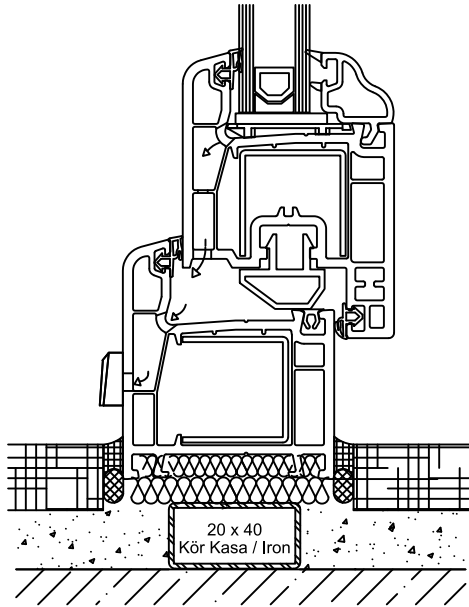
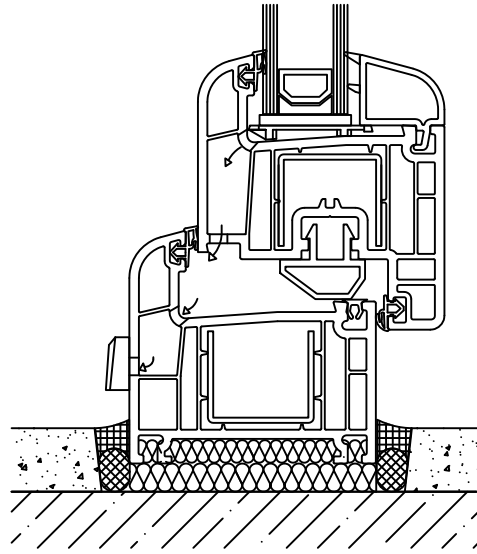
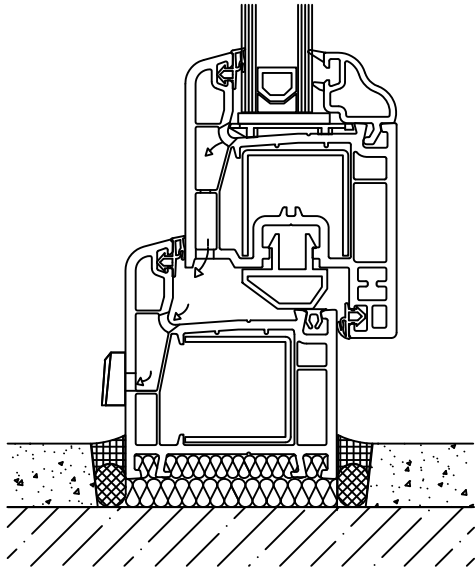

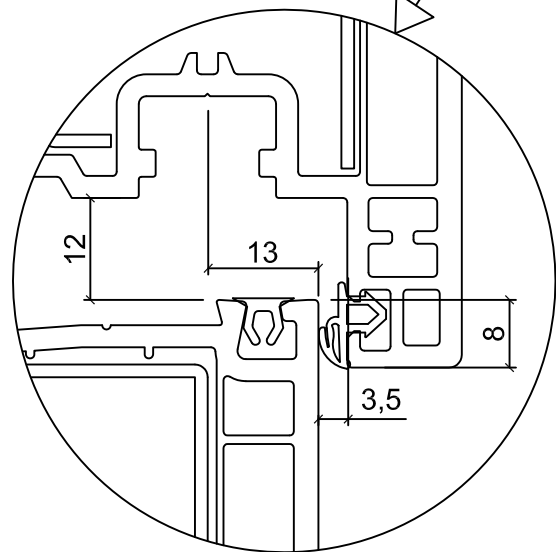
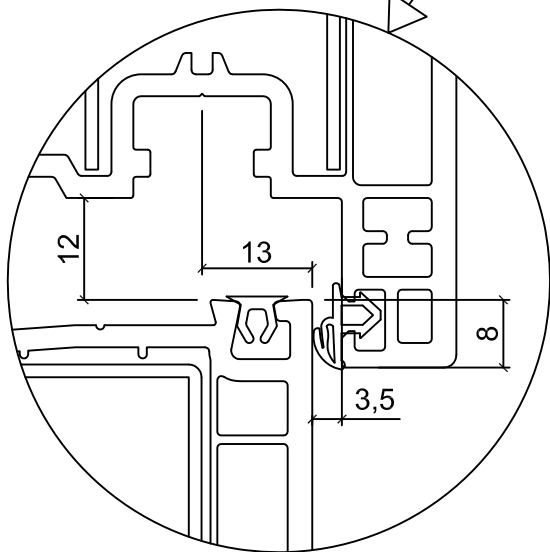
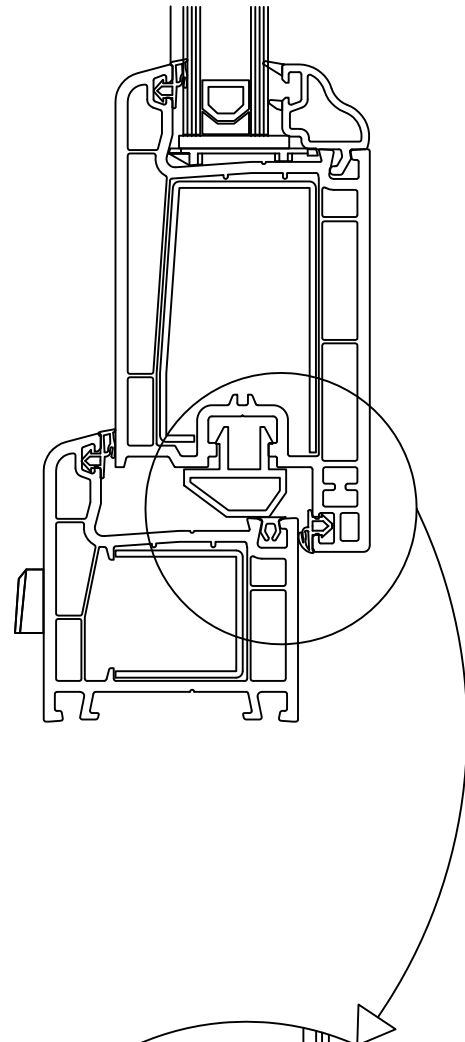
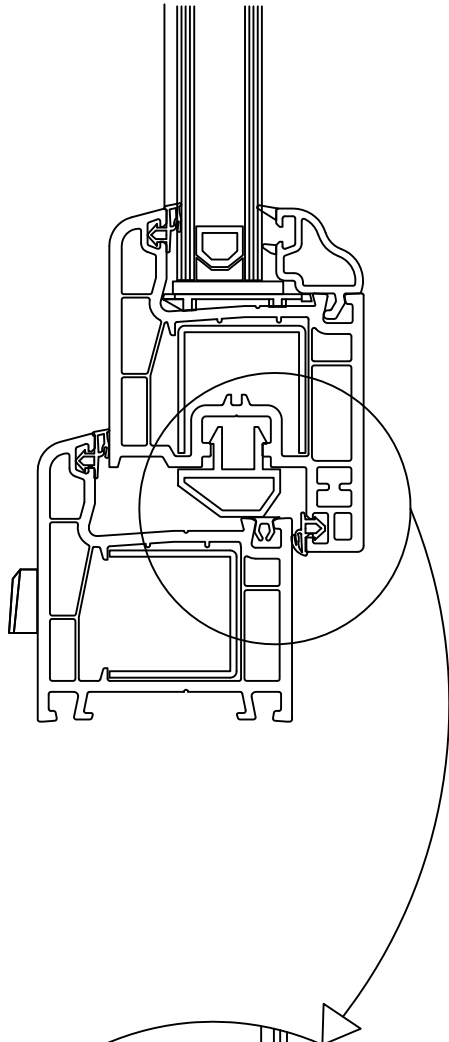

Pencere Kanadı / Window Sash

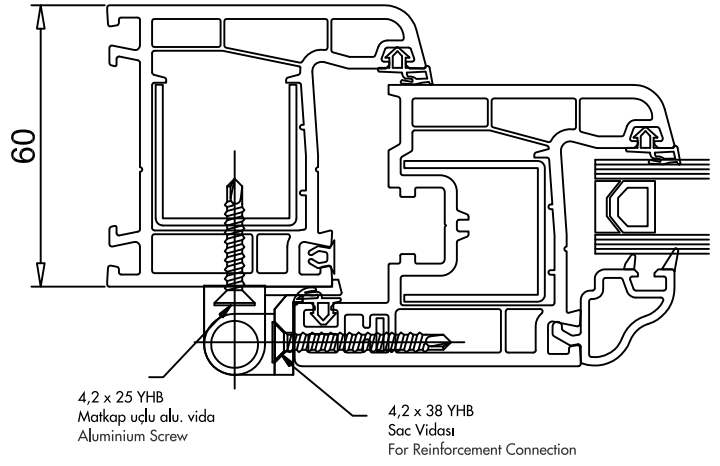
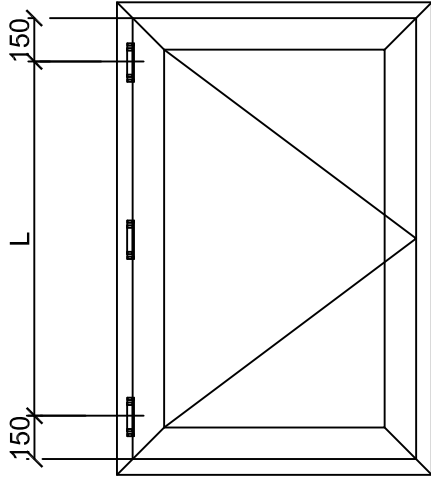

Kapı Kanadı / Door Sash

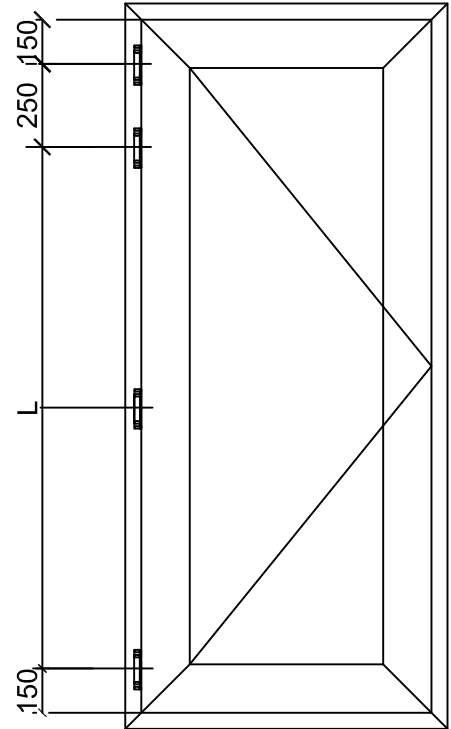
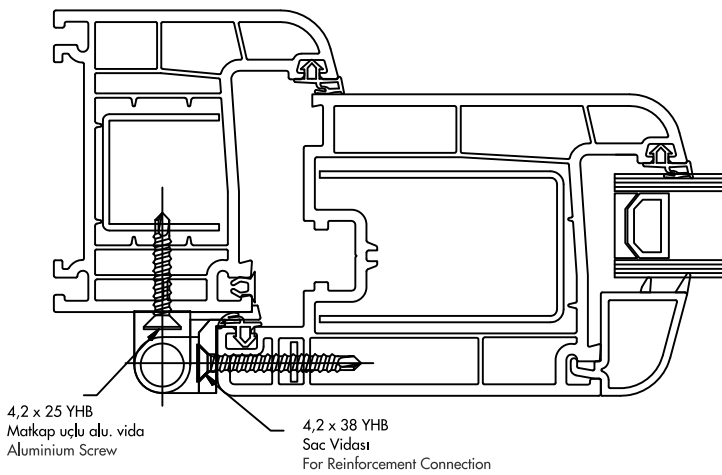

İşlem Sırası

- 1) Destek Sacı Kesilir
- 2) Destek Sacları $\text{Ø } 3,9 \times 16$ YHB matkap uçlu vida ile vidalanır

Processes

- 1) Reinforcement profile cutting
- 2) Screwing reinforcement profile with $\text{Ø } 3,9 \times 16$ YHB

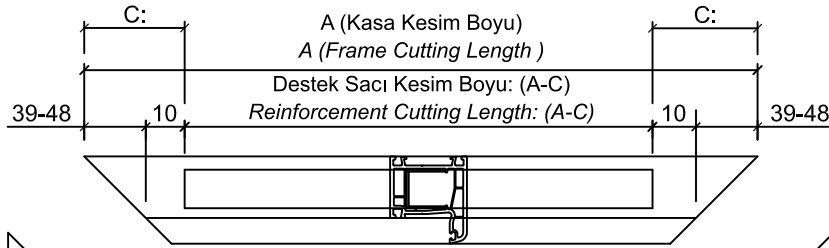
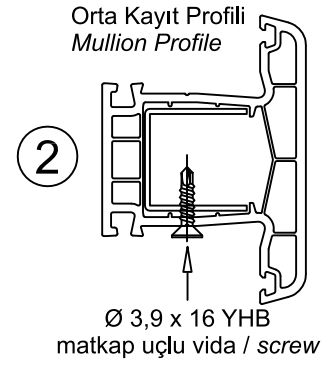
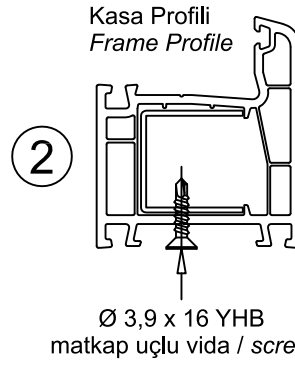

1

Kasa ve Orta Kayıt Destek Sacı Kesim Tablosu
Frame and Mullion Reinforcement Profile Cutting Schedule

Kasa Frame 601	C=98
Kasa Frame 361, 631,701	C=116
Orta Kayıt Mullion 362, 602, 632	D=20

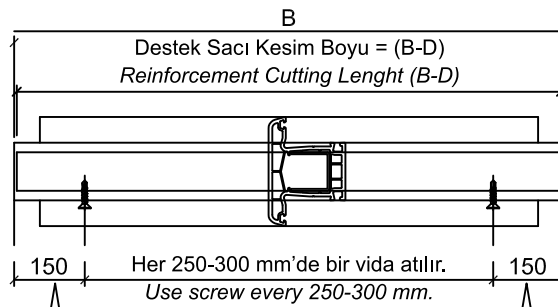
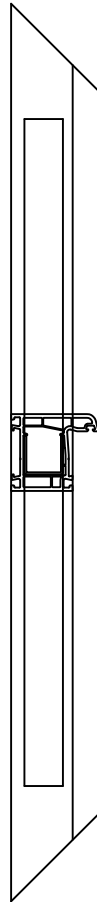

3

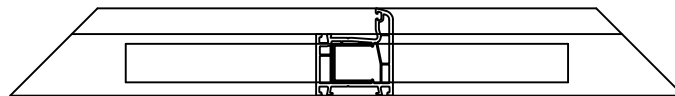
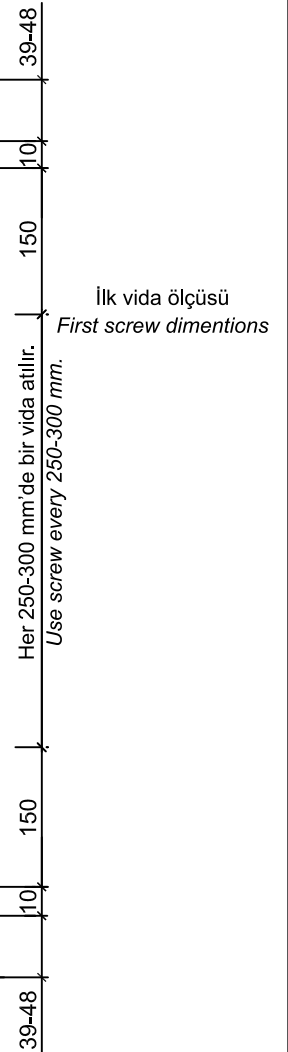
İlk vida ölçüsü
First screw dimensions

Not: - Kesim boyu 500mm'den küçük profillere destek sacı konmaz.
Ancak menteşe tarafında ve renkli profillerin tamamında boy ne olursa olsun destek sacı konacaktır.
- Profiller iç görünüş olarak çizilmiştir.

Not: - If cutting length is less than 500 mm no need to use reinforcement profile. But at the hinge side of the window and all types of laminated profiles, using reinforcement profile is necessary.
- All the views are from inside of the profiles.

İşlem Sırası

- 1) Destek Sacı Kesilir
- 2) Destek Sacları $\text{Ø } 3,9 \times 16$ YHB matkap uçlu vida ile vidalanır

Processes

- 1) Reinforcement profile cutting
- 2) Screwing reinforcement profile with $\text{Ø } 3,9 \times 16$ YHB

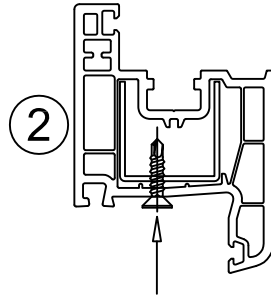
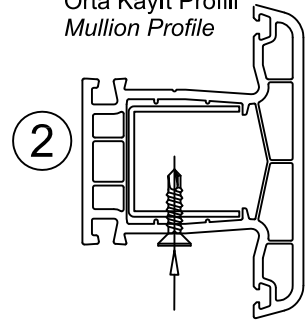
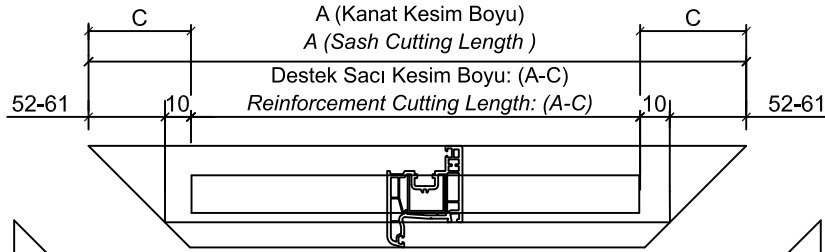
Kanat Profili
Sash Profile $\text{Ø } 3,9 \times 16$ YHB
matkap uçlu vida / screwOrta Kayıt Profili
Mullion Profile $\text{Ø } 3,9 \times 16$ YHB
matkap uçlu vida / screw

1

Kanat ve Orta Kayıt Destek Sacı Kesim Tablosu
Sash and Mullion Reinforcement Profile Cutting Schedule

Kanat Sash 363, 703	C=142
Kanat Sash 603	C=124
Orta Kayıt Mullion 362, 602, 632	D=20

B

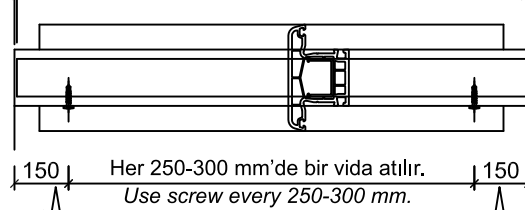
Destek Sacı Kesim Boyu = (B-D)
Reinforcement Cutting Length (B-D)A-VIEW
A-BAKIŞ. 3İlk vida ölçüsü
First screw dimensionsİlk vida ölçüsü
First screw dimensionsHer 250-300 mm'de bir vida atılır.
Use screw every 250-300 mm.Her 250-300 mm'de bir vida atılır.
Use screw every 250-300 mm.

Not: - Kesim boyu 500mm'den küçük profillere destek sacı konmaz.
Ancak menteşe tarafında ve renkli profillerin tamamında boy ne olursa olsun destek sacı konacaktır.
- Profiller iç görünüş olarak çizilmiştir.

Not: - If cutting length is less than 500 mm no need to use reinforcement profile. But at the hinge side of the window and all types of laminated profiles, using reinforcement profile is necessary.
- All the views are from inside of the profiles.

İşlem Sırası

- 1) Destek Sacı Kesilir
- 2) Destek Sacları Ø 3,9 x 16 YHB matkap uçlu vida ile vidalanır

Processes

- 1) Reinforcement profile cutting
- 2) Screwing reinforcement profile with Ø 3,9 x 16 YHB

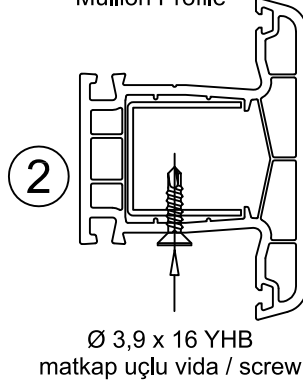
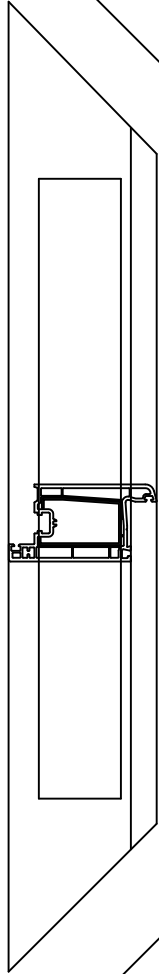
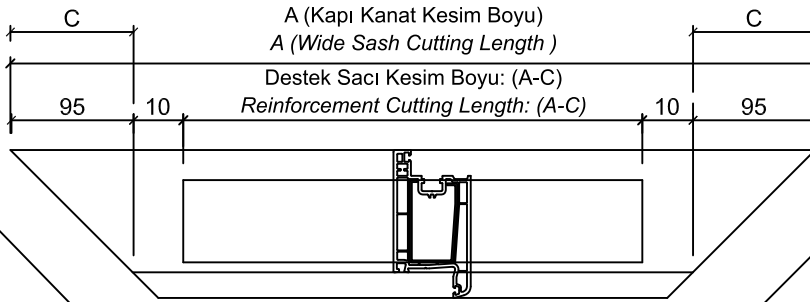
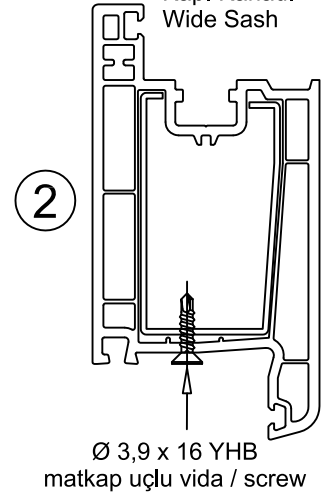
Orta Kayıt Profili
Mullion ProfileKapı Kanadı
Wide Sash

Kanat ve Orta Kayıt Destek Sacı Kesim Tablosu Frame and Mullion Reinforcement Profile Cutting Schedule	
Kapı Kanadı Door Sash Profile 605	C=210
Orta Kayıt Mullion Profile	C=20

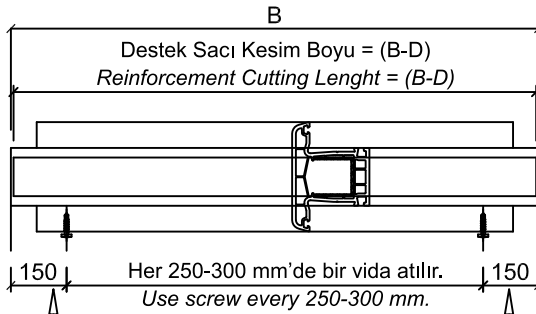
A-VIEW
A-BAKİŞ

3

İlk vida ölçüsü
First screw dimensionsİlk vida ölçüsü
First screw dimensionsHer 250-300 mm'de bir vida atılır.
Use screw every 250-300 mm.

Not: - Kesim boyu 500mm'den küçük profillere destek sacı konmaz. Ancak menteşe tarafında ve renkli profillerin tamamında boy ne olursa olsun destek sacı konacaktır.
- Profiller iç görünüş olarak çizilmiştir.

Not: - If cutting length is less than 500 mm no need to use reinforcement profile. But at the hinge side of the window and all types of laminated profiles, using reinforcement profile is necessary.
- All the views are from inside of the profiles.

İşlem Sırası

- 1) Su tahliye kanalları açılır (Alt ve yatay orta kayıda)
- 2) Vakum delikleri (Şablon yardımıyla) delinir. Vakum delikleri, cam yatağına giren suyun tahliyesi için şarttır.

Processes

- 1) Water discharging channels are opened
- 2) Vacuum holes are bored.

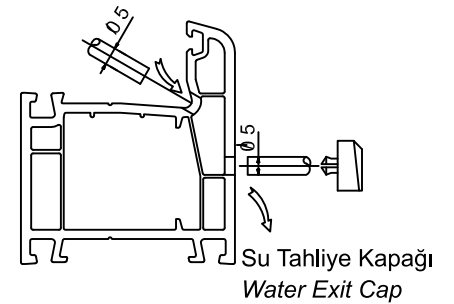
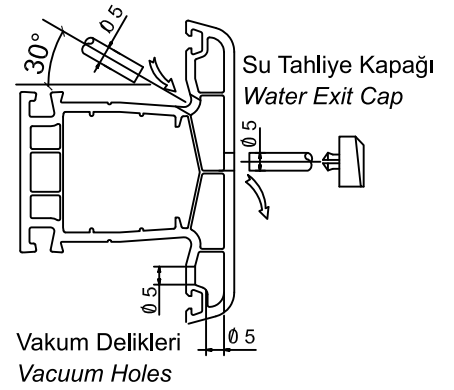
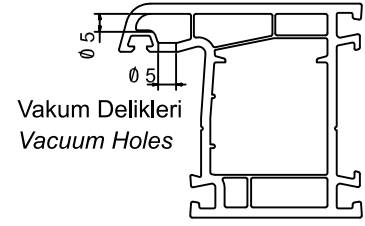
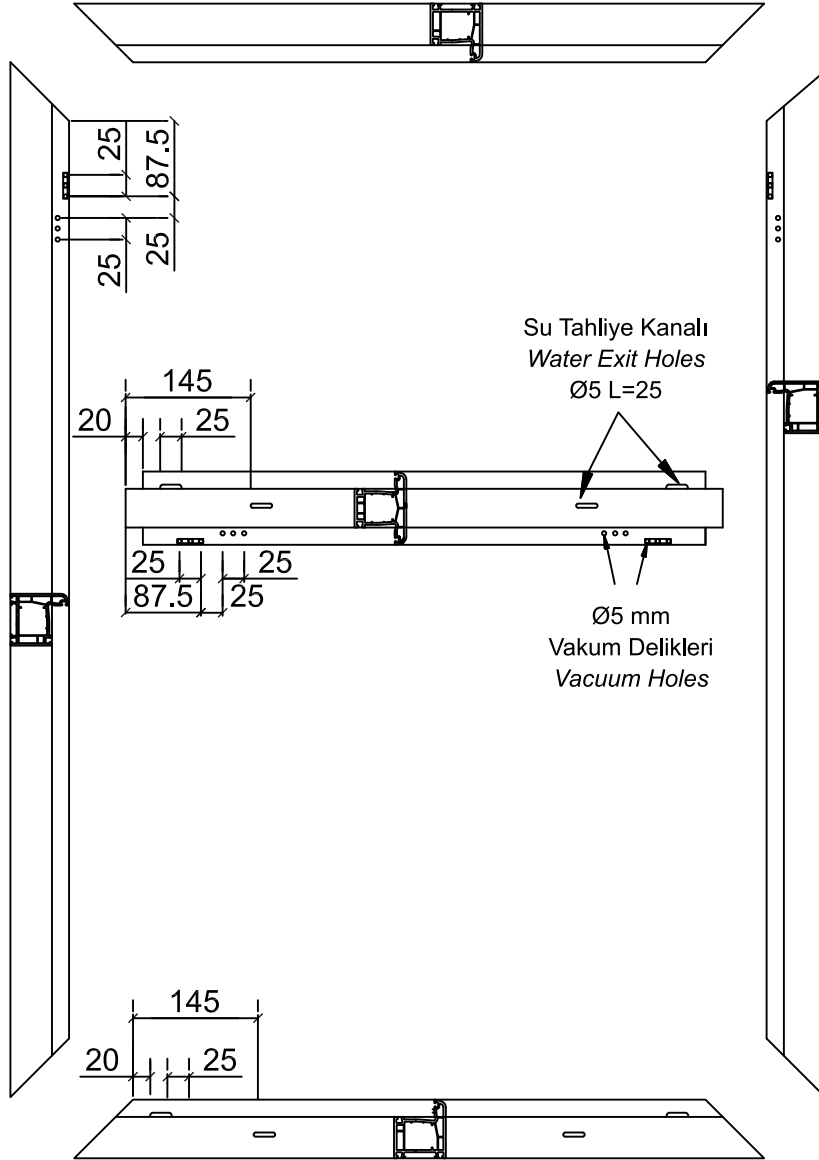

Not: - Profiller iç görünüş olarak çizilmiştir.
- Genişliği 1300mm'den fazla olan kasa ve orta profillerine su tahliye ile vakum delikleri, orta eksene bir giriş bir çıkış olarak şartmalı açılır.

Not: - The drawing og the profiles are inside viewing.
- If the wide of the freme and mullion profile is more than 1300 mm water discharging chenmels and vacuum holes can be opened crosswise on the middle axis of the profile

İşlem Sırası

- 1) Su tahliye kanalları açılır (Alt ve yatay orta kayıda)
- 2) Vakum delikleri (Şablon yardımıyla) delinir. Vakum delikleri, cam yatağına giren suyun tahliyesi için şarttır.

Processes

- 1) Water discharging channels are opened
- 2) Vacuum holes are bored.

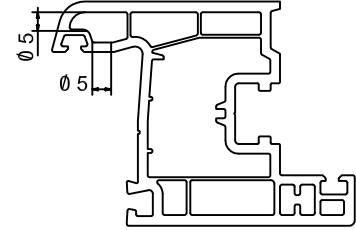
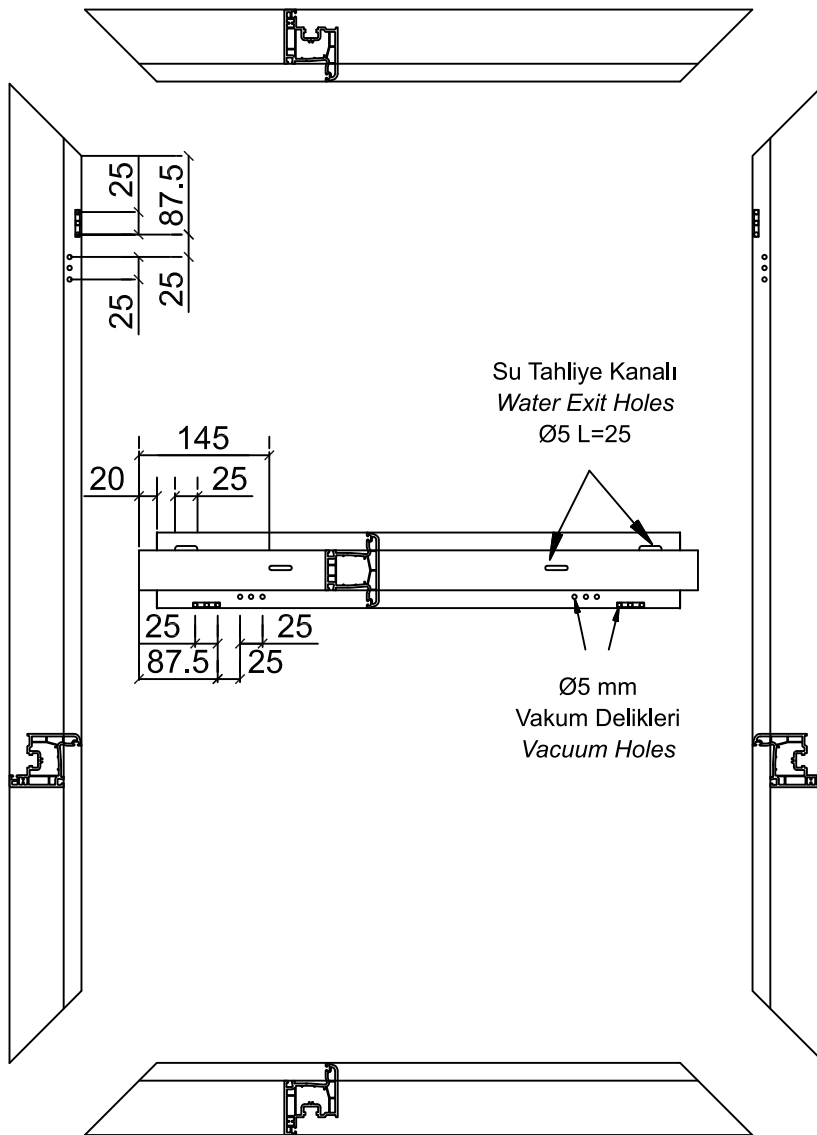
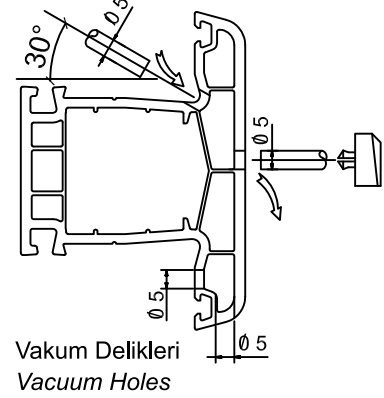
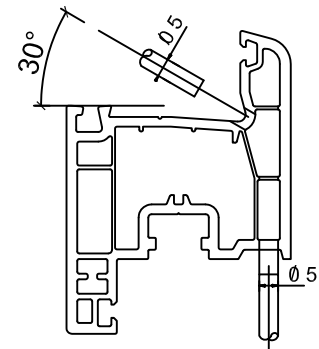
Su Tahliye Kapağı
Water Exit CapVakum Delikleri
Vacuum HolesSu Tahliye Kapağı
Water Exit Cap

Not: - Su tahliye ve vakum delikleri sadece dış cephe kapılarına açılacaktır.
- Profiller iç görünüş olarak çizilmiştir.

Not: - Water discharging channels and vacuum holes can be opened by the outside of the profiles
- The drawing of the profiles are inside winns.

İşlem Sırası

- 1) Destek Sacı Kesilir
- 2) Destek Sacları Ø 3,9 x 16 YHB matkap uçlu vida ile vidalanır

Processes

- 1) Reinforcement profile cutting
- 2) Screwing reinforcement profile with Ø 3,9 x 16 YHB

Kasa Profili
Frame Profile

②

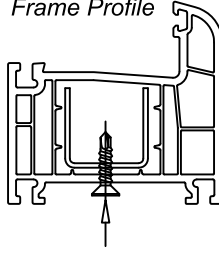
Ø 3,9 x 16 YHB
matkap uçlu vida / screwOrta Kayıt Profili
Mullion Profile

②

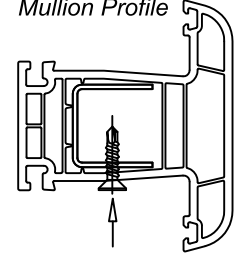
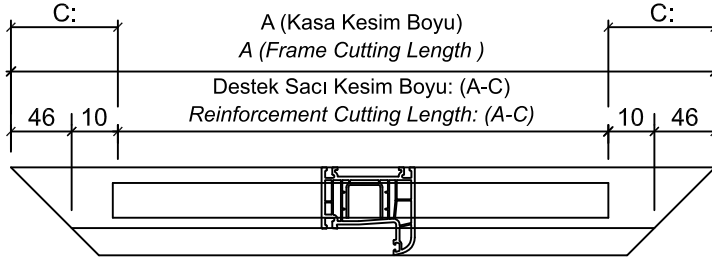
Ø 3,9 x 16 YHB
matkap uçlu vida / screw

①

Kasa ve Orta Kayıt Destek Sacı Kesim Tablosu
Frame and Mullion Reinforcement Profile Cutting Schedule

Kasa Frame	C=112
Orta Kayıt Mullion Profile	C=20

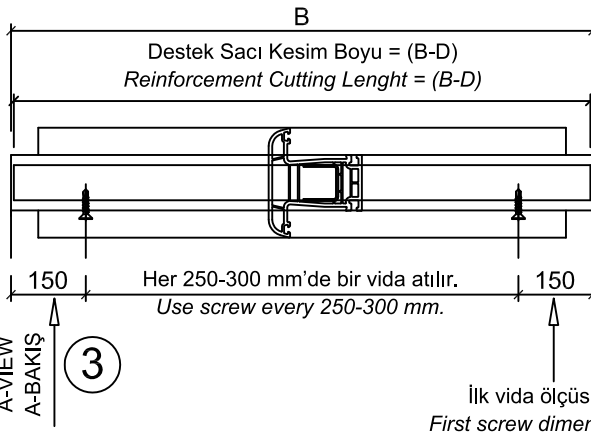
A-VIEW
A-BAKIŞ

③

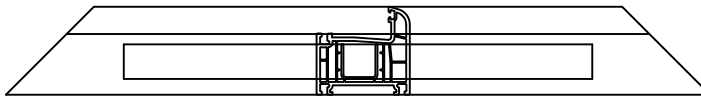
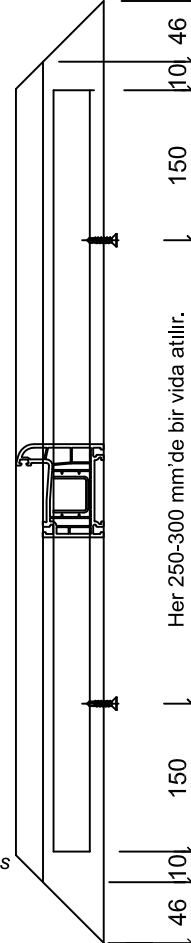
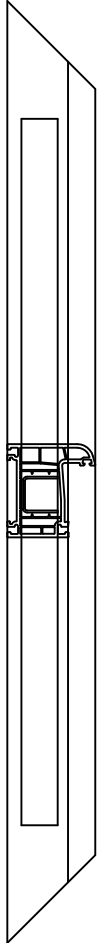

Not: - Kesim boyu 500mm'den küçük profillere destek sacı konmaz. Ancak menteşe tarafında ve renkli profillerin tamamında boy ne olursa olsun destek sacı konacaktır.
- Profiller iç görünüş olarak çizilmiştir.

Not: - If cutting length is less than 500 mm no need to use reinforcement profile. But at the hinge side of the window and all types of laminated profiles, using reinforcement profile is necessary.
- All the views are from inside of the profiles.

İşlem Sırası

- 1) Destek Sacı Kesilir
- 2) Destek Sacları Ø 3,9 x 16 YHB matkap uçlu vida ile vidalanır

Processes

- 1) Reinforcement profile cutting
- 2) Screwing reinforcement profile with Ø 3,9 x 16 YHB

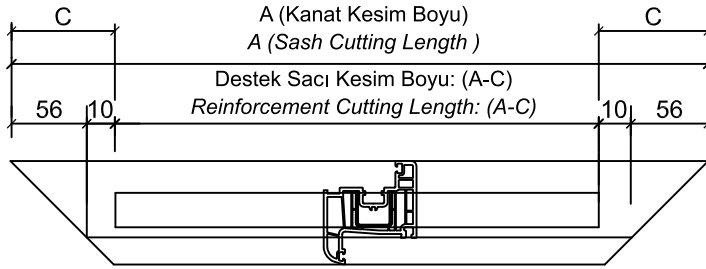
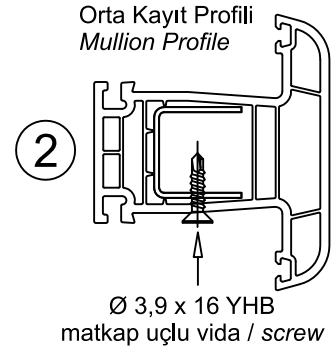
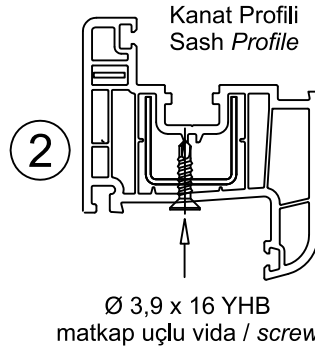

1

Kanat ve Orta Kayıt Destek Sacı Kesim Tablosu
Frame and Mullion Reinforcement Profile Cutting Schedule

Kanat Sash	C=132
Orta Kayıt Mullion Profile	C=20

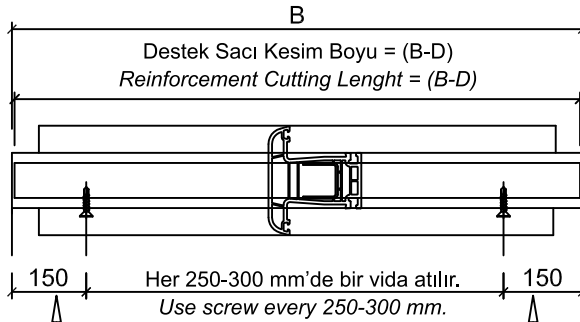
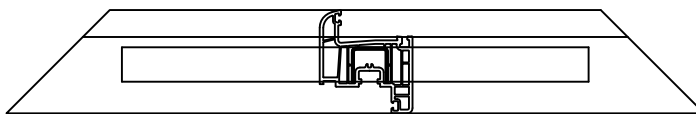
A-VIEW
A-BAKIŞ
3İlk vida ölçüsü
First screw dimensionsİlk vida ölçüsü
First screw dimensionsHer 250-300 mm'de bir vida atılır.
Use screw every 250-300 mm.

Not: - Kesim boyu 500mm'den küçük profillere destek sacı konmaz. Ancak menteşe tarafında ve renkli profillerin tamamında boy ne olursa olsun destek sacı konacaktır.
- Profiller iç görünüş olarak çizilmiştir.

Not: - If cutting length is less than 500 mm no need to use reinforcement profile. But at the hinge side of the window and all types of laminated profiles, using reinforcement profile is necessary.
- All the views are from inside of the profiles.

İşlem Sırası

- 1) Destek Sacı Kesilir
- 2) Destek Sacları Ø 3,9 x 16 YHB matkap uçlu vida ile vidalanır

Processes

- 1) Reinforcement profile cutting
- 2) Screwing reinforcement profile with Ø 3,9 x 16 YHB

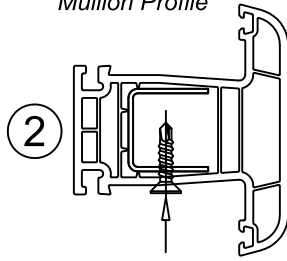
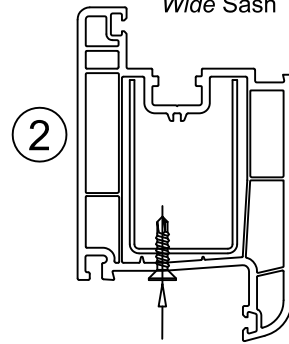
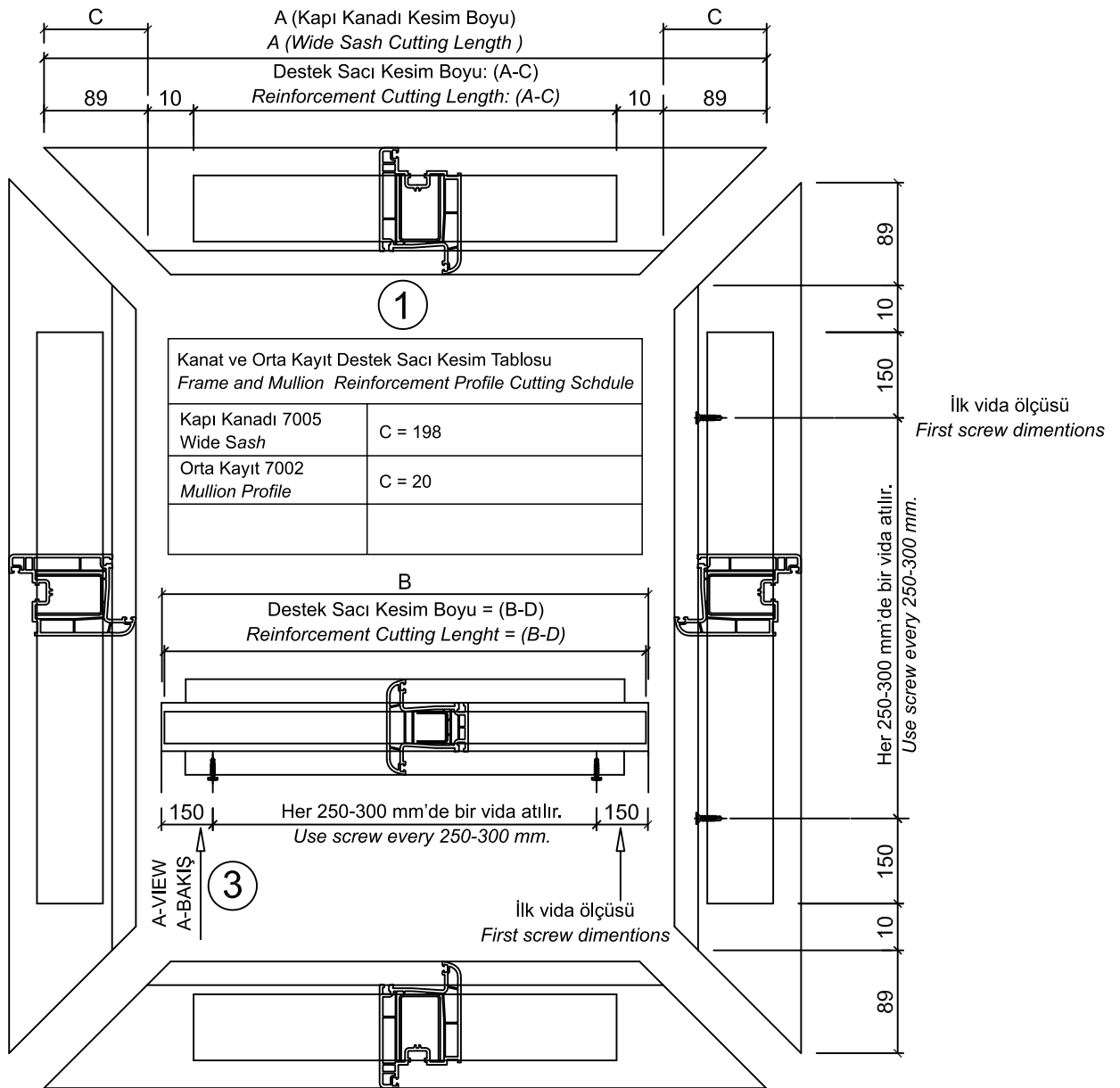
Orta Kayıt Profili
Mullion ProfileØ 3,9 x 16 YHB
matkap uçlu vida / screwKapı Kanadı
Wide SashØ 3,9 x 16 YHB
matkap uçlu vida / screw

Not: - Kesim boyu 500mm'den küçük profillere destek sacı konmaz. Ancak menteşe tarafında ve renkli profillerin tamamında boy ne olursa olsun destek sacı konacaktır.
- Profiller iç görünüş olarak çizilmiştir.

Not: - If cutting length is less than 500 mm no need to use reinforcement profile. But at the hinge side of the window and all types of laminated profiles, using reinforcement profile is a necessity.
- All the views are from inside of the profiles.

İşlem Sırası

- 1) Conta Kanalları Temizlenir
- 2) Contalar kasa ve kanadın üst kenar orta noktasından başlamak üzere, conta kanalına gerdirmeden takılır. Birleştirme noktalarındaki gerginlik alındıktan sonra kesilir.
- 3) Contaların köşe dönüşlerinde açıklık ve bombelik kalmamasına dikkat edilmelidir.

Processes

- 1) Gasket channels are cleaned.
- 2) Gasket assembling is started from the up and middle point of sash and frame profiles. Do not tense the gasket while assembling.
- 3) While turning the corners, please take care for camber at the corners.

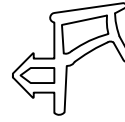
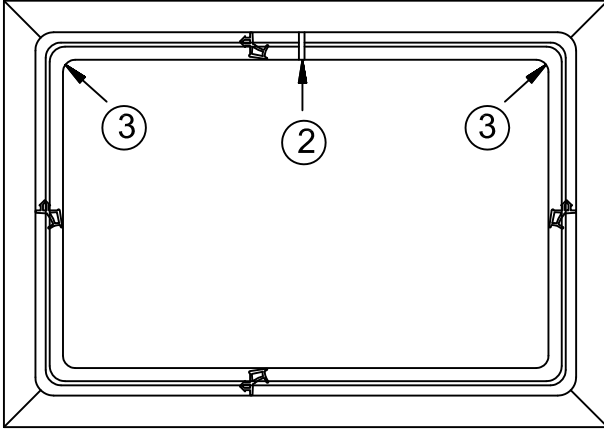

Kasa - Kanat Conta
Frame Sash Gasket

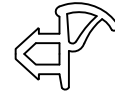

Kanat Conta
Sash Gasket

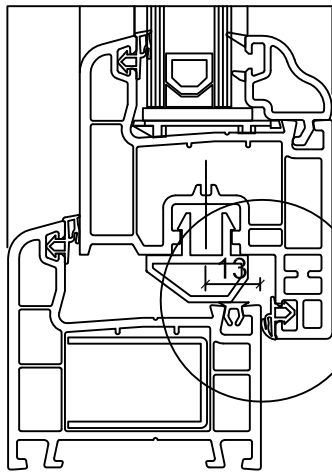

S60

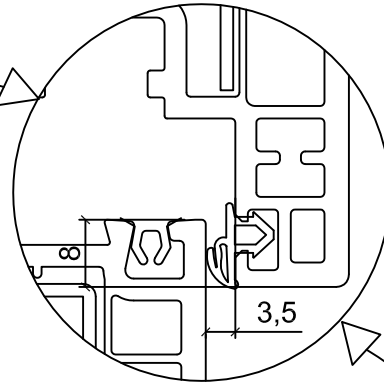

3,5

S70

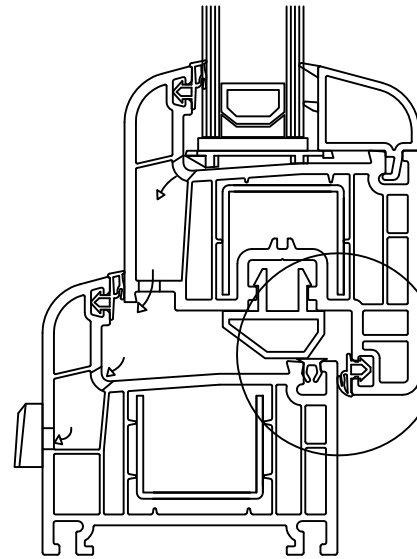

Not: Tüm kapı ve pencerelerde cam conta boşluğu 3,5 mm kanat baskı payı 8mm'dir.

Note: All windows and doors window gasket space is 3,3 mm sash press space is 8 mm

MAX - MiN KANAT EBATLARI
MAX. - MIN. SASH DIMENTIONS

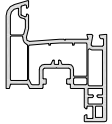
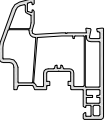
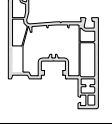
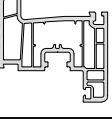
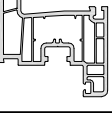
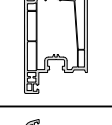
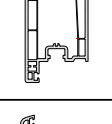
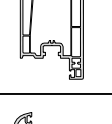
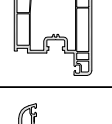
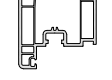
Profil Resmi Profile Picture	Profil No Profile No	Seri Adı Serial Name	Genişlik (mm) Width (mm)		Max Yükseklik Max. Height (mm)
			Min	Max	
	603	S 60	350	900	1400
	703	S 60	350	1000	1500
	633	S 60	350	1000	1500
	7033	S 70	350	1000	1500
	7003	S 70	350	1000	1500
	605	S 60	400	900	2200
	606	S 60	400	900	2200
	607	S 60	400	900	2200
	7005	S 70	400	900	2200
	7006	S 70	400	900	2200

1) Doğrama yapılmadan önce profildeki çatlama ve kırılmaları önlemek ve mukavim kaynak elde etmek için profillerin en az 24 saat oda sıcaklığına (20 C°) olması gerekir.

2) Bu boyutlar, kasa profillerinde destek sacı kalınlığı 1,5 mm olarak hesaplanmıştır.

Dikkat !... *** 2 mm destek sacı; A, B ve C grubuna uygundur. *** 1,5 mm destek sacı yapıldığı takdirde C grubu uygulanmaz.

1) Before production of window, please keep the profiles in room temperature minimum 24 hours

2) These dimensions are calculated for 1,5mm reinforcement profiles

Attention !... *** reinforcement profile is suitable for A,B,C groups. *** 1,5 mm reinforcement can not be used for C group buildings.

Bina yüksekliği / Height of buildings

A Grubu / Group A : 8 mm

B Grubu / Group B : 20 mm

C Grubu / Group C : 100 mm

SERTİFİKALAR
SERTIFICATE

Certificate of Registration



This is to certify that the Quality Management System of
Saray Döküm ve Madeni Aksam Sanayi A. .

Veliköy Sanayi Bölgesi Çerkezköy, Tekirdağ , Turkey

applicable to

**Manufacture of pvc profile systems trading as "sarplas" and "saraypen" and manufacture of
alpeal composite panels trading as "saraybond" and "aluface"**

has been assessed and registered by
National Quality Assurance Limited against the provisions of

BS EN ISO 9001 : 2008

This registration is subject to the company maintaining a quality management system, to the above
standard, which will be monitored by NQA

A handwritten signature in black ink, appearing to read 'C. G. Jones'.

Head of NQA

Certificate No:	17433/1
Date:	01 April 2005
Reissued	09 April 2009
Valid Until:	09 April 2012
EAC code:	14/17



015

Certificate of Registration



Đbu belge,

Saray Döküm ve Madeni Aksam Sanayi A. .

Veliköy Sanayi Bölgesi Çerkezköy, Tekirdađ, Türkiye

Kalite Yönetim Sisteminin

"Sarplas" ve "saraypen" markaları ile pvc profil sistemleri ve "saraybond" and "aluface" markaları ile alpeal kompozit panelleri üretimi

Uygulamasının

BS EN ISO 9001 : 2008

hükümleri geređince National Quality Assurance Limited tarafından denetlendiđini ve tescil edildiđini doğrular.

Bu tescil iđlemi, kuruluşun kalite sistemini, yukarıda anılan standart uyarınca NQA'in denetimi altında sürdürmesine bađlıdır.

Uyumsuzluk halinde bu sertifikanın İngilizce dilindeki yorumu geçerli olacaktır.

Head of NQA

Sertifika no:	17433/1
Tarih:	01 Nisan 2005
Yeniden Yayın:	09 Nisan 2009
Geçerlilik tarihi:	09 Nisan 2012
EAC Kodu:	14/17





TÜRK STANDARDLARI ENSTİTÜSÜ
TÜRK STANDARDLARINA UYGUNLUK BELGESİ
TURKISH STANDARDS INSTITUTION
CERTIFICATE OF CONFORMITY TO TURKISH STANDARDS

Markanın Tanımı Description of the Mark
TSE veya/or  veya/or **T S E**

BELGE NUMARASI : 14.11.34/TSE-7339
REFERENCE NUMBER OF LICENCE
BELGENİN İLK VERİLİŞ TARİHİ : 03/12/2004
DATE OF FIRST ISSUE OF LICENCE
BELGENİN SON GEÇERLİLİK TARİHİ : 03/12/2011
LICENCE VALID UNTIL
BELGE SAHİBİ KURULUŞUN ADI : SARAY DÖKÜM VE MADENİ AKSAM SANAYİ A.Ş.
NAME OF THE LICENCE HOLDER
BELGE SAHİBİ KURULUŞUN ADRESİ : BAĞLAR MAH. OSMANPAŞA CAD. NO:89 34540 GÜNEŞLİ - İSTANBUL / TÜRKİYE
ADDRESS OF THE LICENCE HOLDER
ÜRETİM YERİ ADI : SARAY DÖKÜM VE MADENİ AKSAM SANAYİ A.Ş.
NAME OF THE MANUFACTURING PLACE
ÜRETİM YERİ ADRESİ : VELİKÖY SANAYİ BÖLGESİ ÇERKEZKÖY TEKİRDAĞI / TÜRKİYE
ADDRESS OF THE MANUFACTURING PLACE
İPTAL EDİLEN BELGE NUMARASI (Varsa) :
INDICATION OF SUPERSEDED LICENCE (if any)
TESCİLLİ TİCARİ MARKASI : "SARAY" MARKALI;
REGISTERED TRADE MARK
İLGİLİ TÜRK STANDARDI : TS 5358 EN 12608/29.4.2004
RELATED TURKISH STANDARD

BELGE KAPSAMI
SCOPE OF LICENCE
TS 5358 EN 12608 /NİSAN 2004 "SERT POLİVİNİL Klorür (PVC-U) PROFİLLER-PENCERE VE KAPILARIN FABRİKASYON OLARAK İMALATINDA KULLANILAN -SINIFLANDIRMA ,ÖZELLİKLER VE DENEY YÖNTEMLERİ"
* S-İKLİM BÖLGESİ SINIFI
* II-DARBE, MUKAVEMETİ SINIFI
* A-DIŞ ET KALINLIĞI SINIFI



03/12/2010

Ömer SÖNMEZ
TÜRK STANDARDLARI ENSTİTÜSÜ
İSTANBUL ÜRÜN

*Enstitümüzce verilmekte olan "İmalata Yeterlilik Belgesi" 15.04.2007 tarihinden itibaren BELGELENDİRME MÜDÜRÜ

*Bu belge, belgelendirilen ürünün, üretim yerinin Enstitümüzün belirlediği şartları karşıladığını da gösterir.

TSE Kalite Kampusu İSTANBUL * TSE ÜRÜN BELGELENDİRME MÜDÜRLÜĞÜ ÇAYIROVA TREN İSTASYONU YANI BAYRAMOĞLU
-GEBZE / KOCAELİ * tel: 0262 653 07 52-20 HAT/0312-416 66 98 * faks:0262 653 08 49/0312-416 66 17 * web :www.kampus.tse.org.tr *
e-mail :e-mail:ubm@kampus.tse.org.tr

Bu belge hiç bir surette tahrif edilemez, kısmen veya okunmasını zorlaştıracak şekilde çoğaltılamaz, kızırtı ve silinti yapılamaz.

СИСТЕМА СЕРТИФИКАЦИИ ГОСТ Р
ФЕДЕРАЛЬНОЕ АГЕНТСТВО ПО ТЕХНИЧЕСКОМУ РЕГУЛИРОВАНИЮ И МЕТРОЛОГИИ



СЕРТИФИКАТ СООТВЕТСТВИЯ

№ РОСС TR.AB68.H01687

Срок действия с 12.04.2010 по 11.04.2013

№ 0089231

ОРГАН ПО СЕРТИФИКАЦИИ рег. № РОСС RU.0001.11AB68.

ООО "ПРОММАШ ТЕСТ". Вокзальная пл., д. 2, г. Мытищи, Мытищинский район, Московская область, 141009, тел. +7(495)782-17-08/775-48-45.

ПРОДУКЦИЯ

Профили из поливинилхлорида т.м. "SARAY PVC", "SARAY", "SARPLAS" для блоков оконных и дверных.
Серийный выпуск.

код ОК 005 (ОКП):

57 7200

СООТВЕТСТВУЕТ ТРЕБОВАНИЯМ НОРМАТИВНЫХ ДОКУМЕНТОВ

ГОСТ 30673-99

код ТН ВЭД России:

3916 20 100 0

ИЗГОТОВИТЕЛЬ "SARAY DOKUM VE MADENI AKSAM SANAYI A.S". Адрес: Baglar Mah.Osmanpasa Cad.No.89 Gunesli -ISTANBUL /TURKIYE, Турция. Телефон (+90 212)550 49 47, факс (+90 212)515 81 00.

СЕРТИФИКАТ ВЫДАН "SARAY DOKUM VE MADENI AKSAM SANAYI A.S". Адрес: Baglar Mah.Osmanpasa Cad.No.89 Gunesli -ISTANBUL /TURKIYE, Турция. Телефон (+90 212)550 49 47, факс (+90 212)515 81 00.

НА ОСНОВАНИИ протокола сертификационных испытаний № 3024 от 12.04.2010 г. ООО "АКАДЕМСИБ", рег. № РОСС RU.0001.21AB09, адрес: РФ, 630024, г. Новосибирск, ул. Бетонная, 14; санитарно-эпидемиологического заключения № 77.01.16.229.П.040598.06.07 от 05.06.2007 г., выданного Управлением Федеральной службы по надзору в сфере защиты прав потребителей и благополучия человека по г. Москве

ДОПОЛНИТЕЛЬНАЯ ИНФОРМАЦИЯ Сертификат системы менеджмента качества BS EN ISO 9001:2008 № 17433/1 от 09.04.2009 г., выданный ОС "NQA".

Схема сертификации: 3.



Руководитель органа

подпись

А.А. Румянцев
инициалы, фамилия

Эксперт

подпись

Н.А. Пенский
инициалы, фамилия

Сертификат не применяется при обязательной сертификации



ДЕРЖАВНИЙ КОМІТЕТ УКРАЇНИ З ПИТАНЬ ТЕХНІЧНОГО РЕГУЛЮВАННЯ
ТА СПОЖИВЧОЇ ПОЛІТИКИ
ДЕРЖАВНА СИСТЕМА СЕРТИФІКАЦІЇ УкрСЕПРО

Серія ВВ

СЕРТИФІКАТ ВІДПОВІДНОСТІ

Зареєстровано в Реєстрі за № UA 1.090.0010152-11

Зарегистрирован в Реестре

Термін дії з 02 лютого 2011 р. до 01 лютого 2013 р.

Срок действия с

Продукція Профілі з полівінілхлориду для вікон та дверей систем "Sarplas" та "Saraupen"

Продукция

3916

код УКТ ЗЕД, ТН ЗЕД

код ДКПП, ОКП

Відповідає вимогам

Соответствует требованиям

ДСТУ Б В.2.7-130:2007 "Профілі полівінілхлоридні для огорожувальних будівельних конструкцій. Загальні технічні умови" за п.п. 5.2.3-5.2.5; 5.3.1 (табл. 3, рядки 5 та 7); 5.3.7.

Виробник продукції

Изготовитель продукции

"SARAY DÖKÜM ve MADENİ AKSAM SANAYİ A.Ş."

Bağlar Mahallesi OsmanPaşa Cad. No:89 Güneşli 34540 Istanbul, Туреччина
Адреса виробництва: Veliköy Organize Sanayi Çerkezköy, Tekirdağ, Туреччина

Сертифікат видано

Сертификат выдан

"SARAY DÖKÜM ve MADENİ AKSAM SANAYİ A.Ş."

Bağlar Mahallesi OsmanPaşa Cad. No:89 Güneşli 34540 Istanbul, Туреччина

Додаткова інформація

Дополнительная информация

Профілі з полівінілхлориду для вікон та дверей систем "Sarplas" та "Saraupen", що випускаються серійно з 02.02.2011 р. до 01.02.2013 р. Контроль відповідності сертифікованої продукції вимогам нормативних документів здійснюється шляхом технічного нагляду за сертифікованою продукцією 1 раз на рік.

Сертифікат видано органом з сертифікації

Сертификат выдан органом по сертификации

ДП "Центр з сертифікації будівельних матеріалів, виробів та конструкцій "СЕРПРОКІЇВБУДПРОЕКТ"

01601, м. Київ, вул. Тургенєвська, 38, свідоцтво про уповноваження № UA.PN.090 від 03.12.2009 р. тел. (044) 486-40-85.

На підставі

На основании

Протокол сертифікаційних випробувань № 732 від 31.01.2011 р., виданий Випробувальним Центром ізоляційних матеріалів та захисту трубопроводів від корозії ВАТ "УкрНДІнжпроект", 01601, м. Київ, вул. Тургенєвська, 38, атестат акредитації № UA 6.001.T.248 від 27.11.2001 р. МОЗ України. Висновок державної санітарно-епідеміологічної експертизи № 05.03.02-03/4047 від 30.01.2009 р.; 01021, м. Київ-21, вул. Грушевського, 7. Акт обстеження виробництва від 21.01.2011 р.



[Signature]
підпис

А. А. Сафаров

ініціали, прізвище



Чинність сертифіката відповідності можна перевірити в Реєстрі системи УкрСЕПРО за тел. (044) 537-35-76

№ 637690

SARAY[®] | Mimari Sistemler
Architectural Systems

Osmanpaşa Cad. Bağlar Mah. No:89 Güneşli / İstanbul • Tel: +90 212 550 49 47 - 651 79 25 • Faks: +90 212 515 81 00 • www.saray.com

